

INSTRUCTIONS – PARTS LIST



CONDUCTIVE POLYPROPYLENE*, POLYPROPYLENE AND PVDF

VERDERAIR VA 50

Air-Operated Diaphragm Pumps

819.4496

Rev. ZAL
EN

For fluid transfer applications. For professional use only.

8.3 bar Maximum Fluid Working Pressure

8.3 bar Maximum Air Input Pressure



Important Safety Instructions

Read all warnings and instructions in this manual.
Save these instructions.

Patent No.
CN ZL941026434.4
FR 9408894
JA 35107270
US 5,368,452

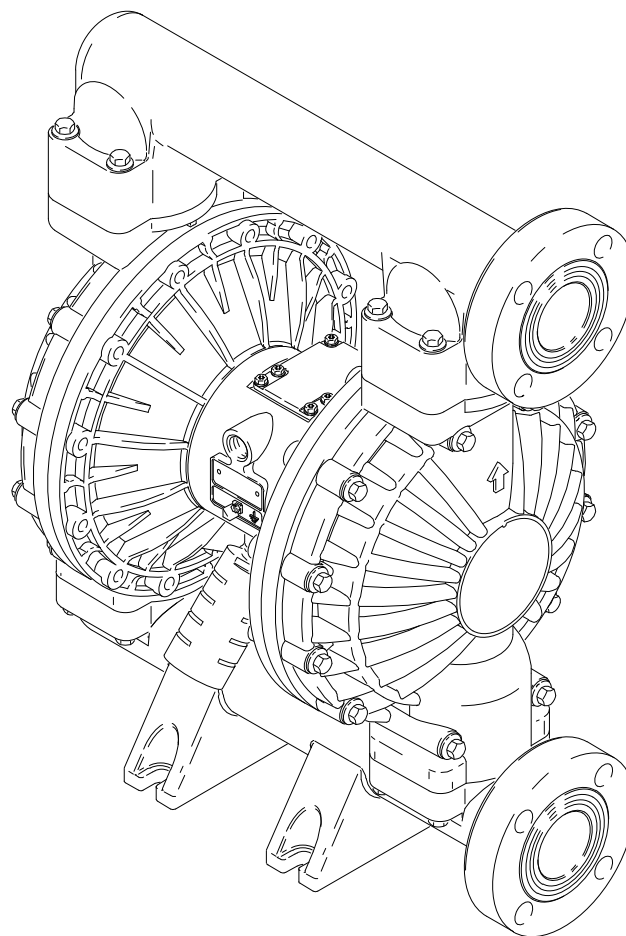

 *
II 2 GD
Ex h IIC 66°C...135°C Gb
Ex h IIIC T135°C Db



*Applies only to pumps with
conductive polypropylene fluid
sections.

04613B

Table of Contents

Symbols	4	Service	16
Installation	6	Repairing the Air Valve	16
Operation	13	Ball Check Valve Repair	18
Pressure Relief Procedure	13	Diaphragm Repair	19
Maintenance	14	Bearing and Air Gasket Removal	23
Troubleshooting	15	Repair Kit Listing	25

Configuration Number Matrix

Check the identification plate (ID) for the 15–digit Configuration Number of your pump. Use the following matrix to define the components of your pump.

Sample Configuration Number: VA50PA – SS TF TF FE 00

VA50	P	A	SS	TF	TF	FE	00
Pump Model	Fluid Section	Air Section	Seats	Checks	Diaphragms	Connections	Options

NOTE: Some combinations are not possible. Please check with your local supplier or www.verderair.com.

Pump Model (1 and 2)	Fluid Section Material (3)		Air Section Material (4)		Seats (5)	
VA50	C	Conductive Polypropylene*	A	Aluminum	BN	Buna–N
	K	PVDF	S	Stainless Steel	HY	TPE
	P	Polypropylene			KY	PVDF
					PP	Polypropylene
					SP	Santoprene
					SS	Stainless Steel
					VT	FKM

Balls (6)		Diaphragm (7)		Connections (8)		Options (9)	
BN	Buna–N	BN	Buna–N	FE	End Flange	00	Standard
GE	Geolast	GE	Geolast			RE	Remote
HY	TPE	HY	TPE				
SP	Santoprene	SP	Santoprene				
TF	PTFE	TF	PTFE/EPDM 2–Piece				
VT	FKM	TO	PTFE/EPDM Overmolded				
		VT	FKM				

*Conductive Polypropylene is certified:  **Ex h IIC 66°C...135°C Gb**
Ex h IIIC T135°C Db

ATEX T-code rating is dependent on the temperature of the fluid being pumped. Fluid temperature is limited by the materials of the pump interior wetted parts. See Technical Data for the maximum fluid operating temperature for your specific pump model.

Symbols

Warning Symbol



This symbol alerts you to the possibility of serious injury or death if you do not follow the instructions.

Caution Symbol



This symbol alerts you to the possibility of damage to or destruction of equipment if you do not follow the instructions.

Warning



INSTRUCTIONS

EQUIPMENT MISUSE HAZARD

Equipment misuse can cause the equipment to rupture or malfunction and result in serious injury.

- This equipment is for professional use only.
- Read all instruction manuals, tags, and labels before operating the equipment.
- Use the equipment only for its intended purpose. If you are not sure, call VERDER After Sales Service.
- Do not alter or modify this equipment.
- Check equipment daily. Repair or replace worn or damaged parts immediately.
- Do not exceed the maximum working pressure of the lowest rated component in your system. This equipment has a **8.3 bar maximum working pressure at 8.3 bar maximum incoming air pressure.**
- Use fluids and solvents which are compatible with the equipment wetted parts. Refer to the **Technical Data** section of all equipment manuals. Read the fluid and solvent manufacturer's warnings.
- Do not use hoses to pull equipment.
- Route hoses away from traffic areas, sharp edges, moving parts, and hot surfaces. Do not expose VERDER hoses to temperatures above 82°C or below -40°C.
- Do not lift pressurized equipment.
- Wear hearing protection when operating this equipment.
- Comply with all applicable local, state, and national fire, electrical, and safety regulations.



Warning

TOXIC FLUID HAZARD



Hazardous fluid or toxic fumes can cause serious injury or death if splashed in the eyes or on the skin, inhaled, or swallowed.



- Know the specific hazards of the fluid you are using.
- Store hazardous fluid in an approved container. Dispose of hazardous fluid according to all local, state, and national guidelines.
- Always wear protective eyewear, gloves, clothing, and respirator as recommended by the fluid and solvent manufacturer.
- Pipe and dispose of the exhaust air safely, away from people, animals, and food handling areas. If the diaphragm fails, the fluid is exhausted along with the air. See **Air Exhaust Ventilation** on page 12.

FIRE AND EXPLOSION HAZARD



Improper grounding, poor ventilation, open flames or sparks can cause a hazardous condition and result in a fire or explosion and serious injury.



- Ground the equipment. Refer to **Grounding** on page 6.
- **Never** use a non-conductive polypropylene or PVDF pump in an explosive atmosphere or with non-conductive flammable fluids as specified by your local fire protection code. Refer to **Grounding** on page 6 for additional information. Consult your fluid supplier to determine the conductivity or resistivity of your fluid.
- If there is any static sparking or you feel an electric shock while using this equipment, **stop pumping immediately**. Do not use the equipment until you identify and correct the problem.
- Provide fresh air ventilation to avoid the buildup of flammable fumes from solvents or the fluid being sprayed, dispensed, or transferred.
- Pipe and dispose of the exhaust air safely, away from all sources of ignition. If the diaphragm fails, the fluid is exhausted along with the air. See **Air Exhaust Ventilation** on page 12.
- Keep the work area free of debris, including solvent, rags, and gasoline.
- Electrically disconnect all equipment in the work area.
- Extinguish all open flames or pilot lights in the work area.
- Do not smoke in the work area.
- Do not turn on or off any light switch in the work area while operating or if fumes are present.
- Do not operate a gasoline engine in the work area.

Installation

General Information

1. The Typical Installation shown in FIG. 2 is only a guide for selecting and installing system components. Contact your VERDER Customer Service for assistance in planning a system to suit your needs.
2. Always use Genuine VERDER Parts and Accessories. Be sure all accessories are adequately sized and pressure-rated to meet the system's requirements.
3. Reference numbers and letters in parentheses refer to the callouts in the figures and the parts lists on pages 28–29.
4. Variations in color between the plastic components of this pump are normal. Color variation does not affect the performance of the pump.

Warning



TOXIC FLUID HAZARD

Hazardous fluid or toxic fumes can cause serious injury or death if splashed in the eyes or on the skin, inhaled, or swallowed.

1. Read **TOXIC FLUID HAZARD** on page 5.
2. Use fluids and solvents which are compatible with the equipment wetted parts. Refer to the **Technical Data** section of all equipment manuals. Read the fluid and solvent manufacturer's warnings.

Tightening Screws Before First Use

Before using the pump for the first time, check and retorque all external fasteners. See **Diaphragm Kits**, page 29. After the first day of operation, retorque the fasteners. Although pump use varies, a general guideline is to retorque fasteners every two months.

Grounding

Warning

FIRE AND EXPLOSION HAZARD



This pump must be grounded. Before operating the pump, ground the system as explained below. Also, read the section **FIRE AND EXPLOSION HAZARD**, on page 5.

The non-conductive polypropylene and PVDF pumps are **not** conductive. Attaching the ground wire to the grounding strip grounds only the air motor.

When pumping conductive flammable fluids, **always** ground the entire fluid system by making sure the fluid has an electrical path to a true earth ground. See FIG. 1.

Never use a non-conductive polypropylene or PVDF pump in an explosive atmosphere or with non-conductive flammable fluids as specified by your local fire protection code.

U.S. Code (NFPA 77 Static Electricity) recommends a conductivity greater than 50×10^{-12} Siemens/meter (mhos/meter) over your operating temperature range to reduce the hazard of fire. Consult your fluid supplier to determine the conductivity or resistivity of your fluid. The resistivity must be less than 2×10^{12} ohm-centimeters.

Installation

Grounding (continued)

To reduce the risk of static sparking, ground the pump and all other equipment used or located in the pumping area. Check your local electrical code for detailed grounding instructions for your area and type of equipment.

Ground all of this equipment:

- *Air Motor:* Connect a ground wire and clamp as shown in FIG. 1. Loosen the grounding screw (W). Insert one end of a 1.5 mm² minimum ground wire (Y) behind the grounding screw and tighten the screw securely. Connect the clamp end of the ground wire to a true earth ground. Order Part No. 819.0157 Ground Wire and Clamp.

NOTE: When pumping conductive flammable fluids with a non-conductive polypropylene or a PVDF pump, **always** ground the entire fluid system. See the **Warning** on page 6.

- *Air and Fluid hoses:* Use only electrically conductive hoses.
- *Air compressor:* Follow the manufacturer's recommendations.

- *All solvent pails used when flushing,* according to local code. Use only metal pails, which are conductive. Do not place the pail on a non-conductive surface, such as paper or cardboard, which interrupts the grounding continuity.
- *Fluid supply container:* Follow local code.

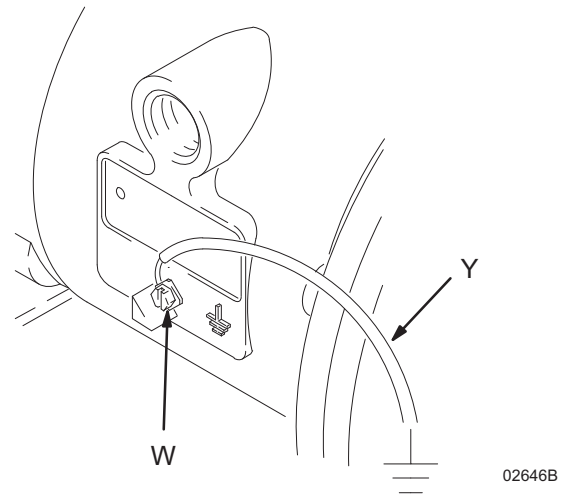

FIG. 1

Installation

Air Line

Warning

A bleed-type master air valve (B) is required in your system to relieve air trapped between this valve and the pump. Trapped air can cause the pump to cycle unexpectedly, which could result in serious injury, including splashing in the eyes or on the skin, injury from moving parts, or contamination from hazardous fluids. See FIG. 2.

1. Install the air line accessories as shown in FIG. 2. Mount these accessories on the wall or on a bracket. Be sure the air line supplying the accessories is electrically conductive.
 - a. Install an air regulator (C) and gauge to control the fluid pressure. The fluid outlet pressure will be the same as the setting of the air regulator.

- b. Locate one bleed-type master air valve (B) close to the pump and use it to relieve trapped air. See the **Warning** at left. Locate the other master air valve (E) upstream from all air line accessories and use it to isolate them during cleaning and repair.
 - c. The air line filter (F) removes harmful dirt and moisture from the compressed air supply.
2. Install an electrically conductive, flexible air hose (A) between the accessories and the 1/2 npt(f) pump air inlet (N). See FIG. 2. Use a minimum 13 mm ID air hose.
3. Screw an air line quick disconnect coupler (D) onto the end of the air hose (A); be sure the coupler porting is large enough to not restrict the air flow, which will affect pump performance. Screw the mating fitting into the pump air inlet snugly. Do not connect the coupler (D) to the fitting until you are ready to operate the pump.

FLOOR MOUNT TYPICAL INSTALLATION

KEY

- A Electrically Conductive Air Supply Hose
- B Bleed-Type Master Air Valve (required for pump)
- C Air Regulator
- D Air Line Quick Disconnect
- E Master Air Valve (for accessories)
- F Air Line Filter
- G Fluid Suction Hose
- H Fluid Supply
- J Fluid Drain Valve (required)
- K Fluid Shutoff Valve
- L Fluid Hose
- N 1/2 npt(f) Air Inlet Port
- R 2 in. Fluid Inlet Flange
- S 2 in. Fluid Outlet Flange
- Y Ground Wire (required; see page 7 for installation instructions)

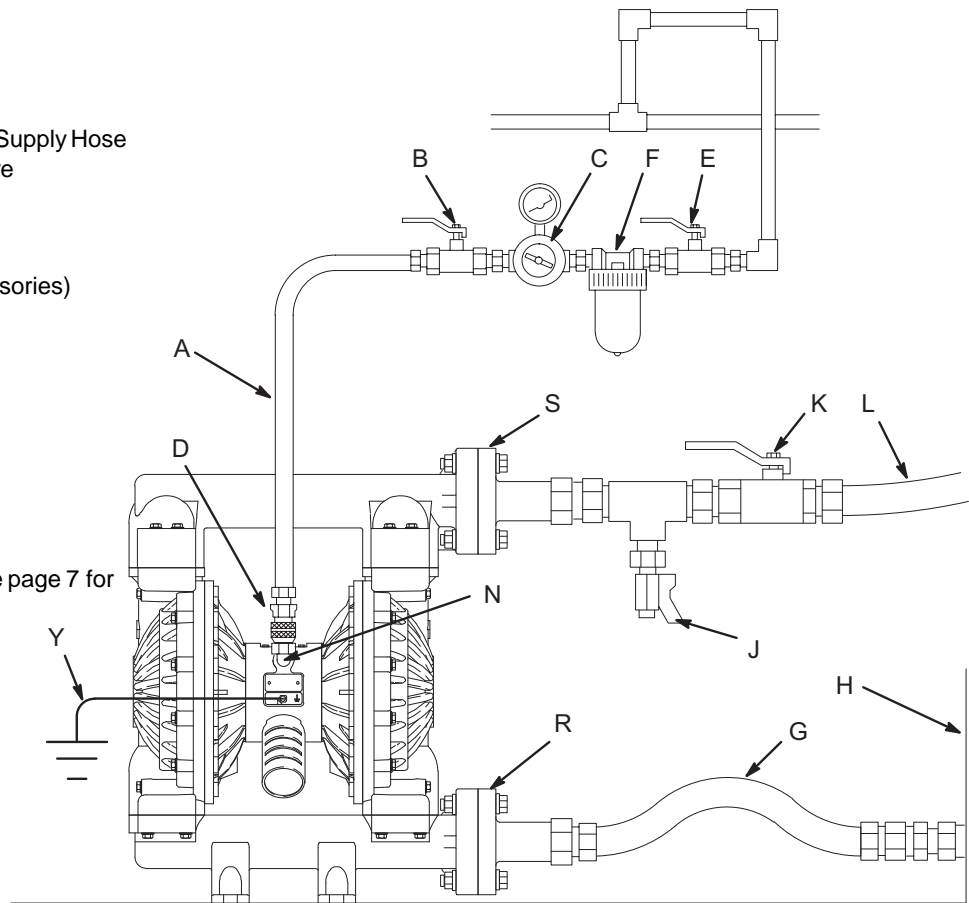

FIG. 2

04614B

Installation

Mountings

Caution

The pump exhaust air may contain contaminants. Ventilate to a remote area if the contaminants could affect your fluid supply. See **Air Exhaust Ventilation** on page 12.

1. Be sure the mounting surface can support the weight of the pump, hoses, and accessories, as well as the stress caused during operation.
2. For all mountings, be sure the pump is bolted directly to the mounting surface.
3. For ease of operation and service, mount the pump so the air valve cover (2), air inlet, and fluid inlet and outlet ports are easily accessible.
4. Rubber Foot Mounting Kit 819.4333 is available to reduce noise and pump movement during operation.
5. Prolonged exposure to UV radiation will degrade natural polypropylene components of the pumps. To prevent potential injury or equipment damage, do not expose pump or the plastic components to direct sunlight for prolonged periods.

Fluid Suction Line

1. The pump fluid inlet (R) is a 2 in. raised face flange. Refer to **Flange Connections** on page 10.

2. If the fluid inlet pressure to the pump is more than 25% of the outlet working pressure, the ball check valves will not close fast enough, resulting in inefficient pump operation.
3. At inlet fluid pressures greater than 1.05 bar, diaphragm life will be shortened.
4. See the **Technical Data** on page 33 for maximum suction lift (wet and dry).

Fluid Outlet Line

Warning

A fluid drain valve (J) is required to relieve pressure in the hose if it is plugged. The drain valve reduces the risk of serious injury, including splashing in the eyes or on the skin, or contamination from hazardous fluids when relieving pressure. Install the valve close to the pump fluid outlet. See FIG. 2.

1. The pump fluid outlet (S) is a 2 in. raised face flange. Refer to **Flange Connections** on page 10.
2. Install a fluid drain valve (J) near the fluid outlet. See the **Warning** above.
3. Install a shutoff valve (K) in the fluid outlet line.

Installation

Flange Connections

The fluid inlet and outlet ports are 2 in. raised face, standard 150 lb class pipe flanges. Connect 2 in. flanged plastic pipe to the pump as follows. You will need:

- torque wrench
- adjustable wrench
- a 6 in. diameter, 1/8 in. thick PTFE gasket, with four 0.75 in. diameter holes on a 4.75 in. diameter bolt circle, and a 2.20 in. diameter center
- four 5/8 in. x 3 in. bolts
- four 5/8 in. spring lockwashers
- eight 5/8 in. flat washers
- four 5/8 in. nuts.

1. Place a flat washer (E) on each bolt (C). Refer to FIG. 3.
2. Align the holes in the gasket (B) and the pipe flange (A) with the holes in the pump outlet flange (S).
3. Lubricate the threads of the four bolts. Install the bolts through the holes and secure with the washers (E), lockwashers (D), and nuts (F).
4. Hold the nuts with a wrench. Refer to the tightening sequence in FIG. 3 and torque the bolts to 27–41 N•m. **Do not over-torque.**
5. Repeat for the pump inlet flange (R).

BOLT TIGHTENING SEQUENCE

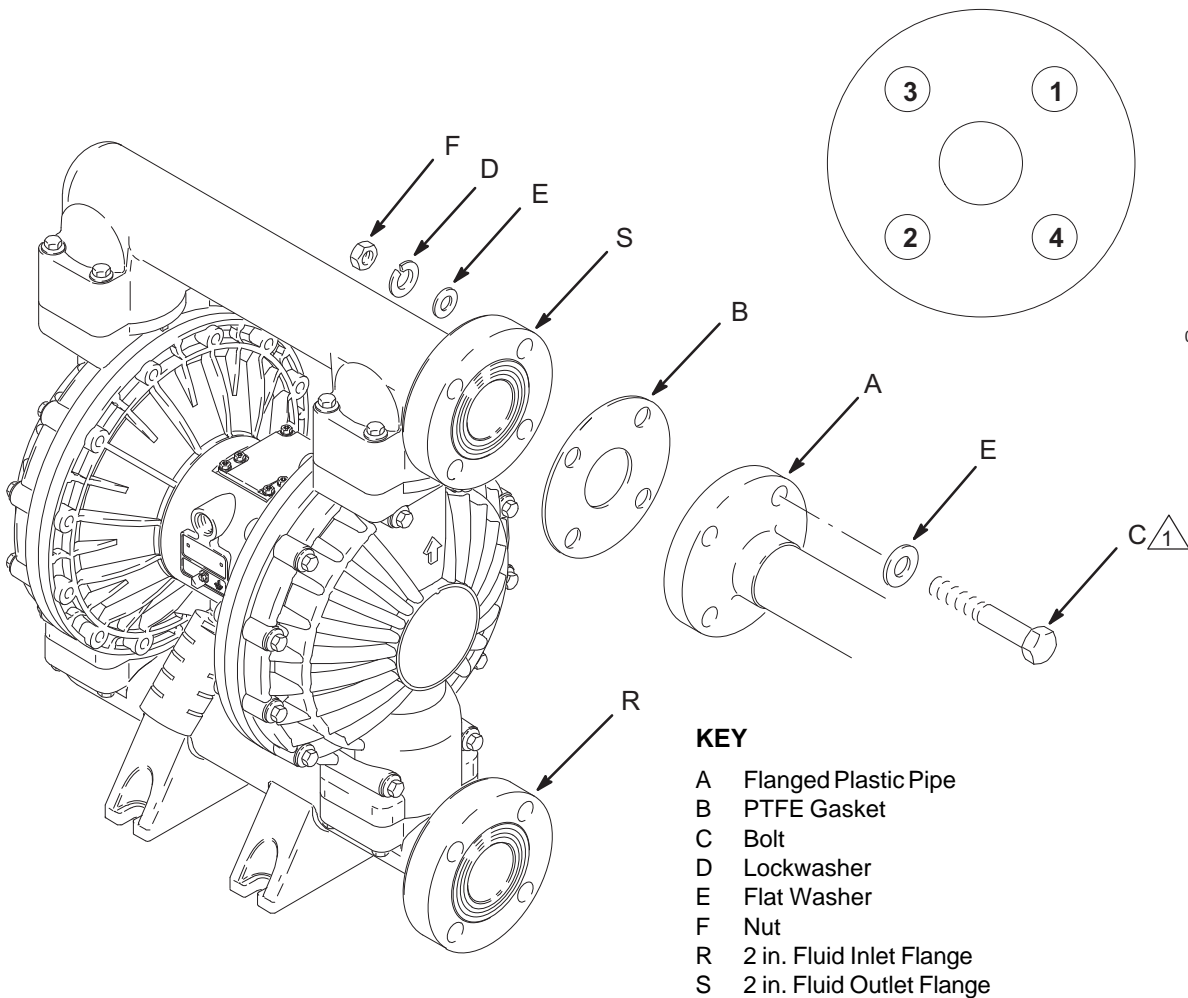

 Lubricate threads. Torque to 27–41 N•m. Do not over-torque.

FIG. 3

04615B

Installation

Changing the Orientation of the Fluid Inlet and Outlet Ports

The pump is shipped with the fluid inlet (R) and outlet (S) ports facing the same direction. See FIG. 4. To change the orientation of the inlet and/or outlet port:

1. Remove the screws and washers (106, 112, 113, and 114) holding the inlet (102) and/or outlet (103) manifold to the covers (101).
2. Reverse the manifold and reattach. Install the screws and torque to 17–18 N•m. See **Diaphragm Kits**, page 29.

KEY

N	1/2 npt(f) Air Inlet Port	106	Fluid Outlet Manifold Screws (Top)
P	Muffler; Air Exhaust Port is 3/4 npt(f)	112	Fluid Inlet Manifold Screws (Bottom)
R	2 in. Fluid Inlet Flange	113	Fluid Outlet Manifold Washers
S	2 in. Fluid Outlet Flange	114	Fluid Inlet Manifold Washers
101	Fluid Covers		
102	Fluid Inlet Manifold		
103	Fluid Outlet Manifold		

⚠ Torque to 17–18 N•m. See **Diaphragm Kits**, page 29.

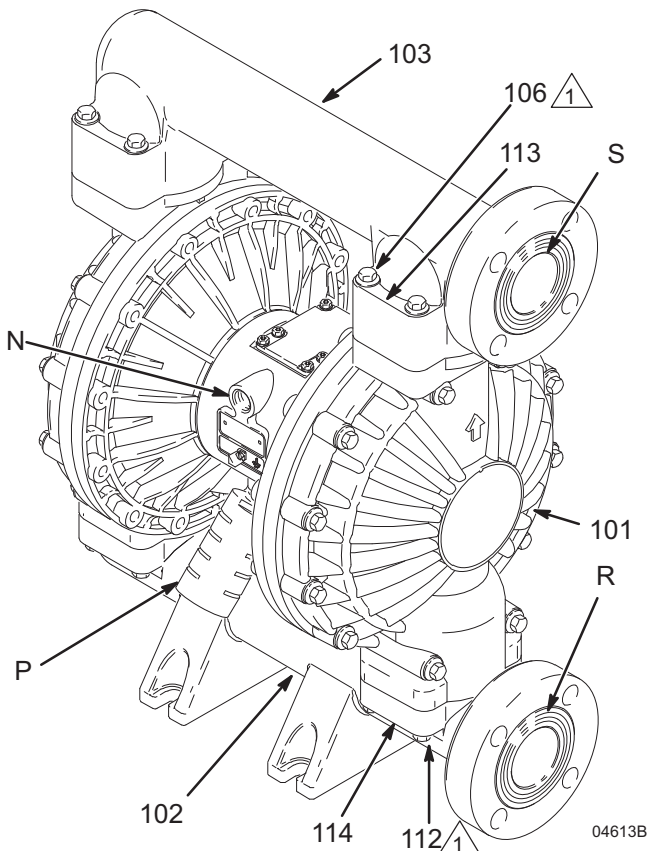

FIG. 4

Fluid Pressure Relief Valve

⚠ Caution

Some systems may require installation of a pressure relief valve at the pump outlet to prevent overpressurization and rupture of the pump or hose. See FIG. 5.

Thermal expansion of fluid in the outlet line can cause overpressurization. This can occur when using long fluid lines exposed to sunlight or ambient heat, or when pumping from a cool to a warm area (for example, from an underground tank).

Overpressurization can also occur if the VERDEAIR pump is being used to feed fluid to a piston pump, and the intake valve of the piston pump does not close, causing fluid to back up in the outlet line.

KEY

R	2 in. Fluid Inlet Flange
S	2 in. Fluid Outlet Flange
V	Pressure Relief Valve Part No. 819.0159 (Stainless Steel)

⚠ 1 Install valve between fluid inlet and outlet ports.

⚠ 2 Connect fluid inlet line here.

⚠ 3 Connect fluid outlet line here.

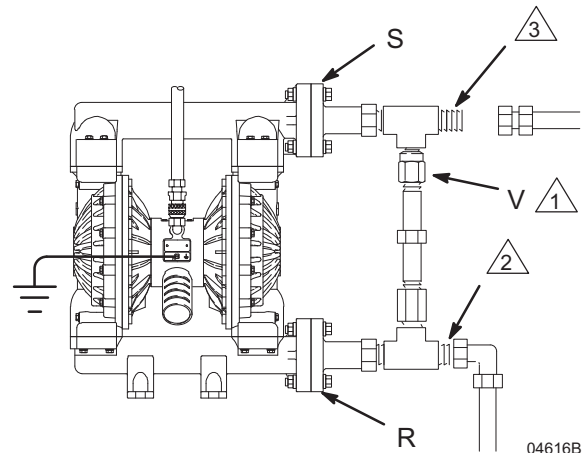

FIG. 5

Installation

Air Exhaust Ventilation

Warning

FIRE AND EXPLOSION HAZARD



Be sure to read and follow the warnings and precautions regarding **TOXIC FLUID HAZARD**, and **FIRE AND EXPLOSION HAZARD** on page 5, before operating this pump.

Be sure the system is properly ventilated for your type of installation. You must vent the exhaust to a safe place, away from people, animals, food handling areas, and all sources of ignition when pumping flammable or hazardous fluids.

Diaphragm failure will cause the fluid being pumped to exhaust with the air. Place an appropriate container at the end of the air exhaust line to catch the fluid. See FIG. 6.

The air exhaust port is 3/4 npt(f). Do not restrict the air exhaust port. Excessive exhaust restriction can cause erratic pump operation.

If the muffler (P) is installed directly to the air exhaust port, apply PTFE thread tape or anti-seize lubricant to the muffler threads before assembly.

To provide a remote exhaust:

1. Remove the muffler (P) from the pump air exhaust port.
2. Install an electrically conductive air exhaust hose (T) and connect the muffler (P) to the other end of the hose. The minimum size for the air exhaust hose is 19 mm ID. If a hose longer than 4.57 m is required, use a larger diameter hose. Avoid sharp bends or kinks in the hose. See FIG. 6.
3. Place a container (U) at the end of the air exhaust line to catch fluid in case a diaphragm ruptures.

VENTING EXHAUST AIR

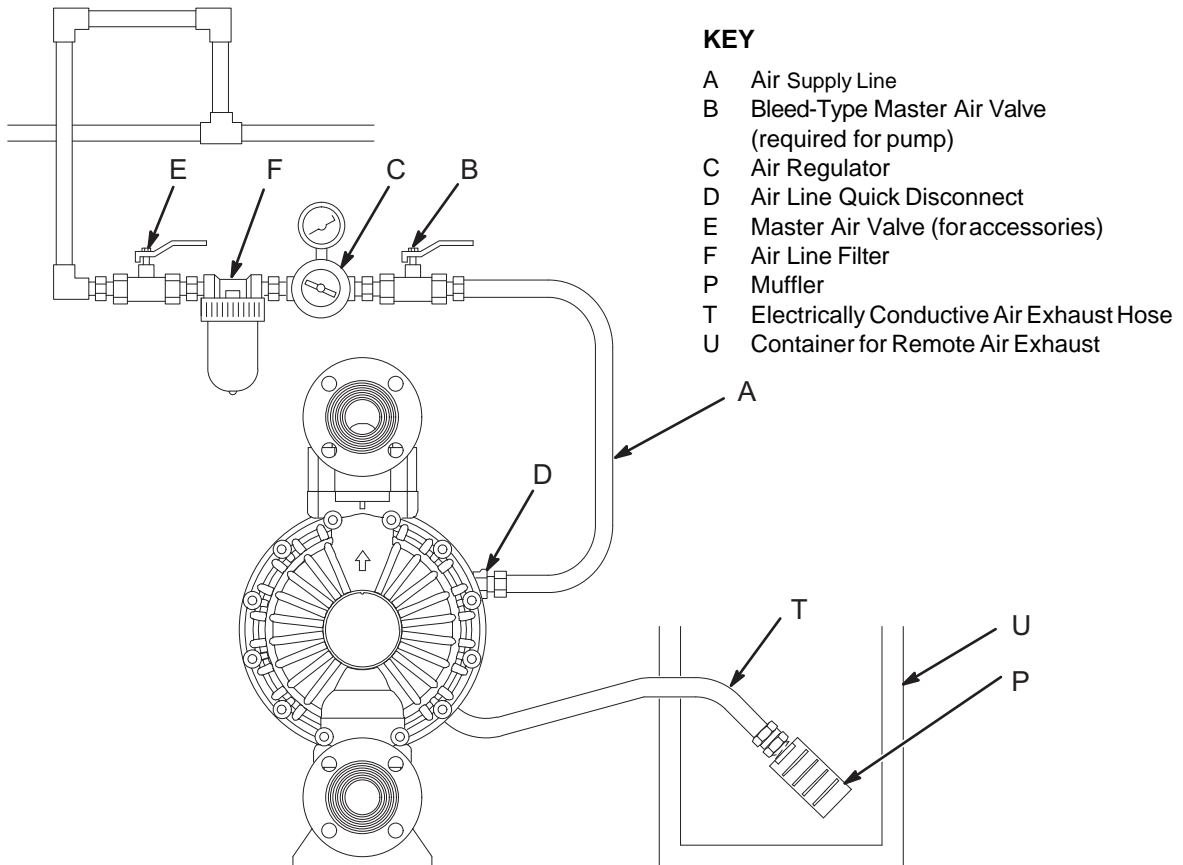

FIG. 6

04617

Operation

Pressure Relief Procedure

Warning

PRESSURIZED EQUIPMENT HAZARD

The equipment stays pressurized until pressure is manually relieved. To reduce the risk of serious injury from pressurized fluid, accidental spray from the gun or splashing fluid, follow this procedure whenever you:

- Are instructed to relieve pressure,
 - Stop pumping,
 - Check, clean or service any system equipment,
 - Install or clean fluid nozzles.
1. Shut off the air to the pump.
 2. Open the dispensing valve, if used.
 3. Open the fluid drain valve to relieve all fluid pressure, having a container ready to catch the drainage.

Flush the Pump Before First Use

The pump was tested in water. If water could contaminate the fluid you are pumping, flush it thoroughly with a compatible solvent. Follow the steps under **Starting and Adjusting the Pump**.

Starting and Adjusting the Pump

Warning

TOXIC FLUID HAZARD



Hazardous fluid or toxic fumes can cause serious injury or death if splashed in the eyes or on the skin, inhaled, or swallowed. Do not lift a pump under pressure. If dropped, the fluid section may rupture. Always follow the **Pressure Relief Procedure** above before lifting the pump.

1. Be sure the pump is properly grounded. Refer to **Grounding** on page 6.
2. Check all fittings to be sure they are tight. Be sure to use a compatible liquid thread sealant on all male threads. Tighten the fluid inlet and outlet fittings securely.
3. Place the suction tube (if used) in the fluid to be pumped.

NOTE: If the fluid inlet pressure to the pump is more than 25% of the outlet working pressure, the ball check valves will not close fast enough, resulting in inefficient pump operation.

4. Place the end of the fluid hose (L) into an appropriate container.
5. Close the fluid drain valve (J). See FIG. 2.
6. With the pump air regulator (C) closed, open all bleed type master air valves (B, E).
7. If the fluid hose has a dispensing device, hold it open while continuing with the following step.
8. Slowly open the air regulator (C) until the pump starts to cycle. Allow the pump to cycle slowly until all air is pushed out of the lines and the pump is primed.

If you are flushing, run the pump long enough to thoroughly clean the pump and hoses. Close the air regulator. Remove the suction tube from the solvent and place it in the fluid to be pumped.

Pump Shutdown

Warning

To reduce the risk of serious injury whenever you are instructed to relieve pressure, always follow the **Pressure Relief Procedure** at left.

At the end of the work shift, relieve the pressure.

Maintenance

Lubrication

The air valve is designed to operate unlubricated. However, if lubrication is desired, every 500 hours of operation (or monthly) remove the hose from the pump air inlet and add two drops of machine oil to the air inlet.

Caution

Do not over-lubricate the pump. Oil is exhausted through the muffler, which could contaminate your fluid supply or other equipment. Excessive lubrication can also cause the pump to malfunction.

Flushing and Storage

Warning

To reduce the risk of serious injury whenever you are instructed to relieve pressure, always follow the **Pressure Relief Procedure** on page 13.

Flush the pump often enough to prevent the fluid you are pumping from drying or freezing in the pump and damaging it. Flush with a fluid that is compatible with the fluid you are pumping and with the wetted parts in your system. Check with your fluid manufacturer or supplier for recommended flushing fluids and flushing frequency.

Always flush the pump and relieve the pressure before storing it for any length of time.

Tightening Threaded Connections

Before each use, check all hoses for wear or damage, and replace as necessary. Check to be sure all threaded connections are tight and leak-free. Check fasteners. Tighten or retorque as necessary. Although pump use varies, a general guideline is to retorque fasteners every two months. See **Diaphragm Kits**, page 29.

Preventive Maintenance Schedule

Establish a preventive maintenance schedule, based on the pump's service history. This is especially important for prevention of spills or leakage due to diaphragm failure.

Troubleshooting

 **Warning**

To reduce the risk of serious injury whenever you are instructed to relieve pressure, always follow the **Pressure Relief Procedure** on page 13.

1. Relieve the pressure before checking or servicing the equipment.
2. Check all possible problems and causes before disassembling the pump.

PROBLEM	CAUSE	SOLUTION
Pump cycles at stall or fails to hold pressure at stall.	Worn check valve balls (301), seats (201) or o-rings (202).	Replace. See page 18.
Pump will not cycle, or cycles once and stops.	Air valve is stuck or dirty.	Disassemble and clean air valve. See pages 16–17. Use filtered air.
	Check valve ball (301) severely worn and wedged in seat (201) or manifold (102 or 103).	Replace ball and seat. See page 18.
	Check valve ball (301) is wedged into seat (201), due to overpressurization.	Install Pressure Relief Valve (see page 11).
	Dispensing valve clogged.	Relieve pressure and clear valve.
Pump operates erratically.	Clogged suction line.	Inspect; clear.
	Sticky or leaking balls (301).	Clean or replace. See page 18.
	Diaphragm ruptured.	Replace. See pages 19–22.
	Restricted exhaust.	Remove restriction.
Air bubbles in fluid.	Diaphragm ruptured.	Replace. See pages 19–22.
	Loose inlet manifold (102), damaged seal between manifold and seat (201), damaged o-rings (202).	Tighten manifold bolts (112) or replace seats (201) or o-rings (202). See page 18.
	Loose fluid side diaphragm plate (105).	Tighten or replace. See pages 19–22.
Fluid in exhaust air.	Diaphragm ruptured.	Replace. See pages 19–22.
	Loose fluid side diaphragm plate (105).	Tighten or replace. See pages 19–22.
Pump exhausts excessive air at stall.	Worn air valve block (7), o-ring (6), plate (8), pilot block (18), u-cups (10), or pilot pin o-rings (17).	Inspect; replace. See pages 16–17.
	Worn shaft seals (402).	Replace. See pages 19–22.
Pump leaks air externally.	Air valve cover (2) or air valve cover screws (3) are loose.	Tighten screws. See page 17.
	Air valve gasket (4) or air cover gasket (22) is damaged.	Inspect; replace. See pages 16–17, 23–24.
	Air cover screws (25) are loose.	Tighten screws. See pages 23–24.
Pump leaks fluid externally from ball check valves.	Loose manifolds (102, 103), damaged seal between manifold and seat (201), damaged o-rings (202).	Tighten manifold bolts (106 and 112) or replace seats (201) or o-rings (202). See page 18.

Service

Repairing the Air Valve

Tools Required

- Torque wrench
- Torx (T20) screwdriver or 7 mm socket wrench
- Needle-nose pliers
- O-ring pick
- Lithium base grease

NOTE: Air Valve Repair Kits 819.4274 (aluminum center housing models) and 819.0249 (stainless steel center housing models) are available. Refer to page 28. Parts included in the kit are marked with a symbol, for example (4†■). Use all the parts in the kit for the best results.

Disassembly

Warning

To reduce the risk of serious injury whenever you are instructed to relieve pressure, always follow the **Pressure Relief Procedure** on page 13.

1. **Relieve the pressure.**
2. With a Torx (T20) screwdriver or 7 mm socket wrench, remove the six screws (3), air valve cover (2), and gasket (4). See FIG. 7.
3. Move the valve carriage (5) to the center position and pull it out of the cavity. Remove the valve block (7) and o-ring (6) from the carriage. Using a needle-nose pliers, pull the pilot block (18) straight up and out of the cavity. See FIG. 8.
4. Pull the two actuator pistons (11) out of the bearings (12). Remove the u-cup packings (10) from the pistons. Pull the pilot pins (16) out of the bearings (15). Remove the o-rings (17) from the pilot pins. See FIG. 9.
5. Inspect the valve plate (8) in place. If damaged, use a Torx (T20) screwdriver or 7 mm socket wrench to remove the three screws (3). Remove the valve plate (8) and, on aluminum center housing models, remove the seal (9). See FIG. 10.
6. Inspect the bearings (12, 15) in place. See FIG. 9. The bearings are tapered and, if damaged, must be removed from the outside. This requires disassembly of the fluid section. See page 23.
7. Clean all parts and inspect for wear or damage. Replace as needed. Reassemble as explained on page 17.

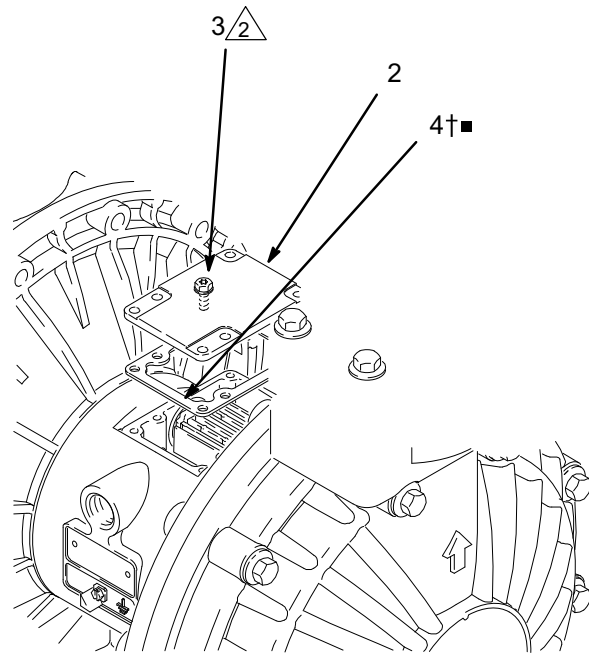

△ Torque to 5.6–6.8 N•m.

04618B

FIG. 7



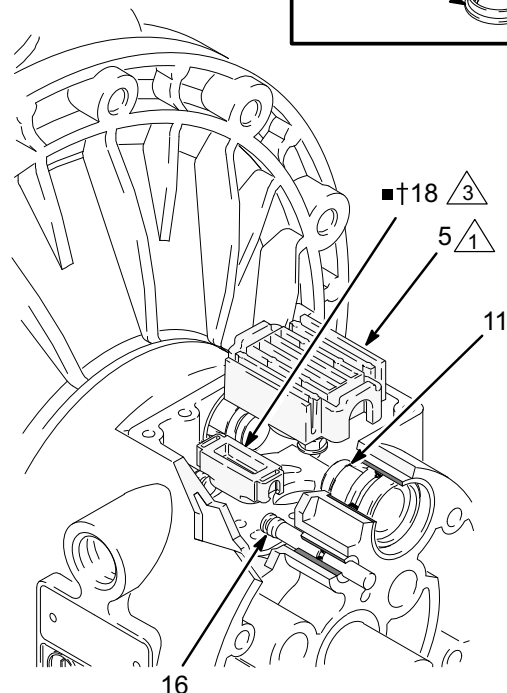
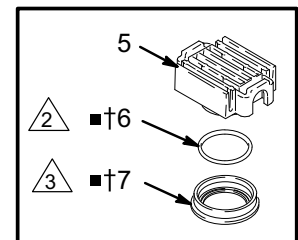

- △ See Detail at right.
- △ Grease.
- △ Grease lower face.



04900B

FIG. 8

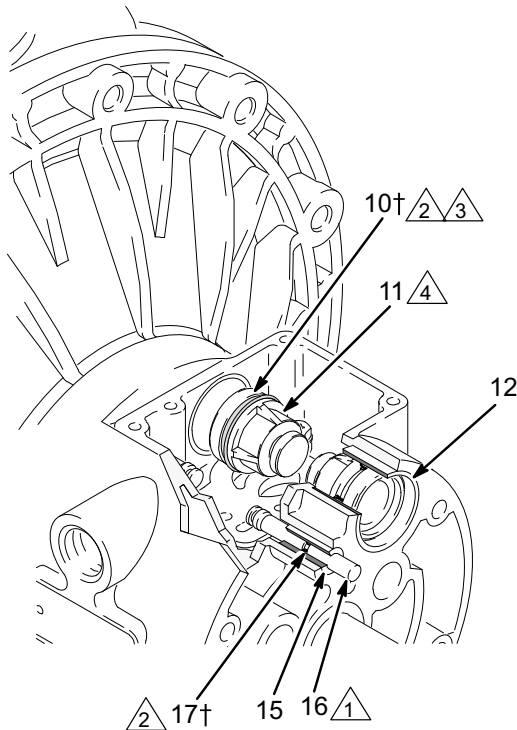

Service

-  Insert narrow end first.
-  Install with lips facing narrow end of piston (11).
-  Grease.
-  Insert wide end first.



04901B

FIG. 9

-  Rounded side must face down.
-  Tighten screws until they bottom out on the housing.

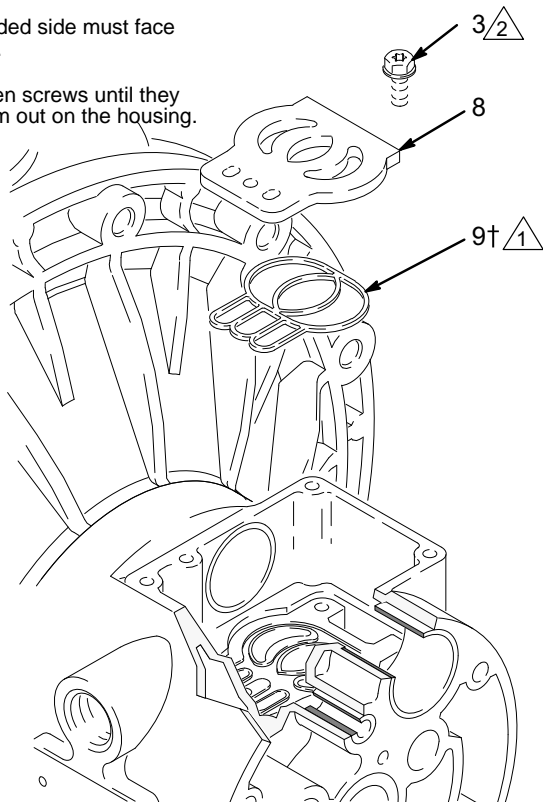

03947

FIG. 10

Reassembly

1. *If you removed the bearings (12, 15),* install new ones as explained on page 23. Reassemble the fluid section.
2. On aluminum center housing models, install the valve plate seal (9†) into the groove at the bottom of the valve cavity. The rounded side of the seal **must face down** into the groove. See FIG. 10.
3. Install the valve plate (8) in the cavity. On aluminum center housing models, the plate is reversible, so either side can face up. Install the three screws (3), using a Torx (T20) screwdriver or 7 mm socket wrench. Tighten until the screws bottom out on the housing. See FIG. 10.
4. Install an o-ring (17†) on each pilot pin (16). Grease the pins and o-rings. Insert the pins into the bearings (15), **narrow** end first. See FIG. 9.
5. Install a u-cup packing (10†) on each actuator piston (11), so the lips of the packings face the **narrow** end of the pistons. See FIG. 9.
6. Lubricate the u-cup packings (10†) and actuator pistons (11). Insert the actuator pistons in the bearings (12), **wide** end first. Leave the narrow end of the pistons exposed. See FIG. 9.
7. Grease the lower face of the pilot block (18†) and install so its tabs snap into the grooves on the ends of the pilot pins (16). See FIG. 8.
8. Grease the o-ring (6†) and install it in the valve block (7†). Push the block onto the valve carriage (5). Grease the lower face of the valve block. See FIG. 8.
9. Install the valve carriage (5) so its tabs slip into the grooves on the narrow end of the actuator pistons (11). See FIG. 8.
10. Align the valve gasket (4†) and cover (2) with the six holes in the center housing (1). Secure with six screws (3), using a Torx (T20) screwdriver or 7 mm socket wrench. Torque to 5.6–6.8 N•m. See FIG. 7.

Service

Ball Check Valve Repair

Tools Required

- Torque wrench
- 10 mm socket wrench
- O-ring pick

Disassembly

NOTE: A Fluid Section Repair Kit is available. Refer to page 25 to order the correct kit for your pump. Parts included in the kit are marked with an asterisk, for example (201*). Use all the parts in the kit for the best results.

NOTE: To ensure proper seating of the balls (301), always replace the seats (201) when replacing the balls.

Warning

To reduce the risk of serious injury whenever you are instructed to relieve pressure, always follow the **Pressure Relief Procedure** on page 13.



1. **Relieve the pressure.** Disconnect all hoses.
2. Remove the pump from its mounting.
3. Using a 10 mm socket wrench, remove the eight bolts (106) and four washers (113), holding the outlet manifold (103) to the fluid covers (101). See FIG. 11.
4. Remove the seats (201), balls (301), and o-rings (202) from the manifold.

NOTE: Some models do not use o-rings (202).

5. Turn the pump over and remove the bolts (112), washers (114), and inlet manifold (102). Remove the seats (201), balls (301), and o-rings (202) from the fluid covers (101).

Reassembly

1. Clean all parts and inspect for wear or damage. Replace parts as needed.
2. Reassemble in the reverse order, following all notes in FIG. 11. Be sure the ball checks are assembled **exactly** as shown. The arrows (A) on the fluid covers (101) **must** point toward the outlet manifold (103).

-  1 Torque to 17–18 N•m. See **Diaphragm Kits**, page 29.
-  2 Arrow (A) must point toward outlet manifold (103).
-  3 Not used on some models.

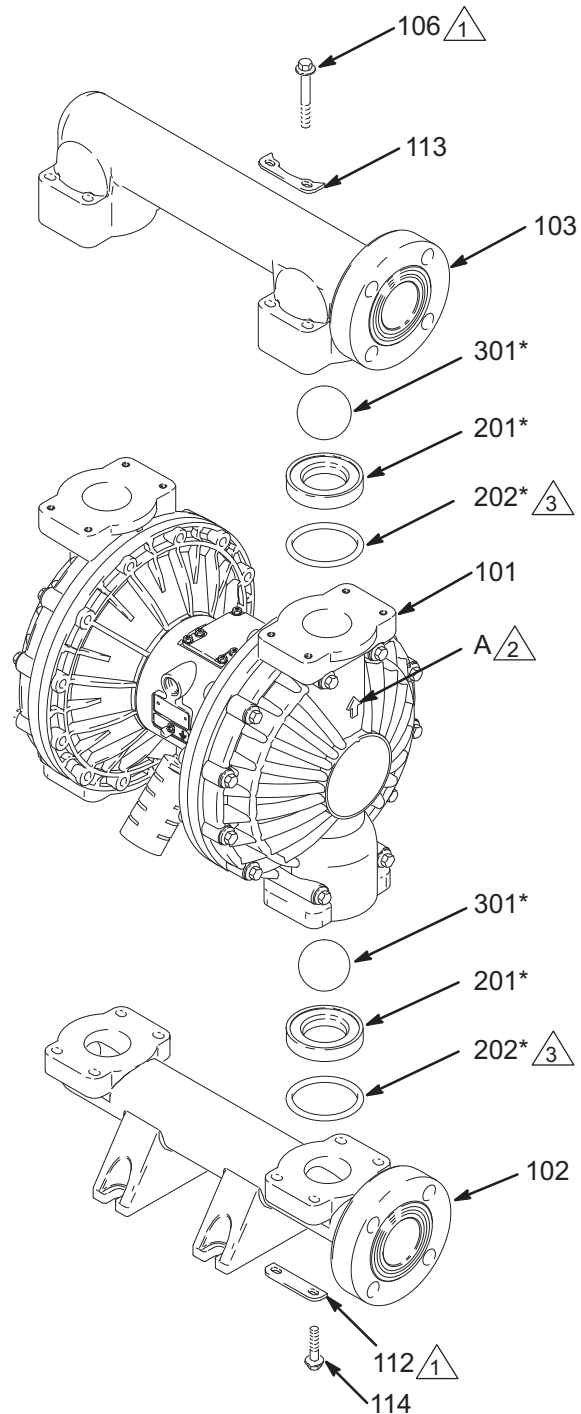

04619C

FIG. 11

Service

Diaphragm Repair

Tools Required

- Torque wrench
- 13 mm socket wrench
- Adjustable wrench
- 19 mm open-end wrench
- O-ring pick
- Lithium-base grease

Disassembly

NOTE: A Fluid Section Repair Kit is available. Refer to page 25 to order the correct kit for your pump. Parts included in the kit are marked with an asterisk, for example (401*). Use all the parts in the kit for the best results.

⚠ Warning

To reduce the risk of serious injury whenever you are instructed to relieve pressure, always follow the **Pressure Relief Procedure** on page 13.

1. **Relieve the pressure.**
2. Remove the manifolds and disassemble the ball check valves as explained on page 18.
3. Using 13 mm socket wrenches, remove the screws (107 and 108) holding the fluid covers (101) to the air covers (23). Pull the fluid covers (101) off the pump. See FIG. 12.

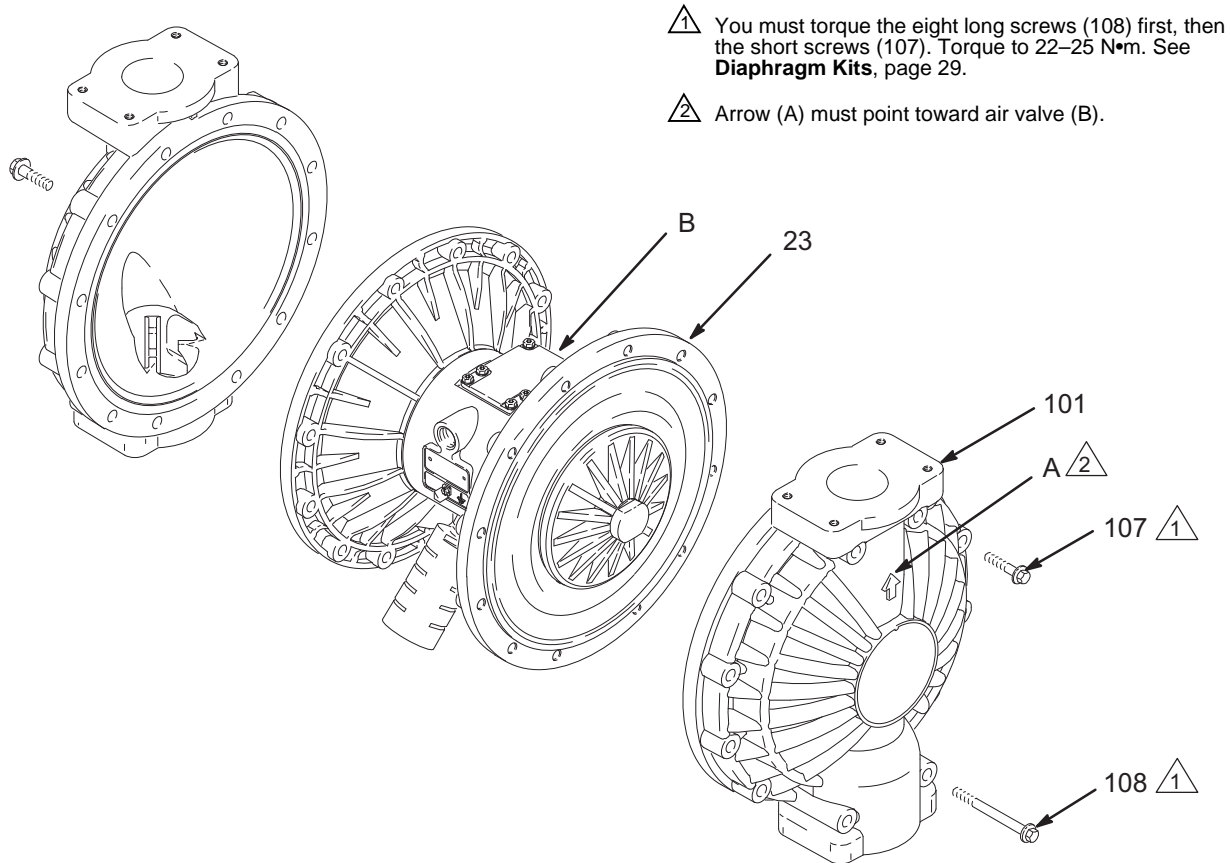

- ⚠ 1 You must torque the eight long screws (108) first, then the short screws (107). Torque to 22–25 N•m. See **Diaphragm Kits**, page 29.
- ⚠ 2 Arrow (A) must point toward air valve (B).

04620B

FIG. 12

Service

4. Unscrew one outer plate (105) from the diaphragm shaft (24). Remove one diaphragm (401), and the inner plate (104). See FIG. 13.

For overmolded diaphragms: Grip both diaphragms securely around the outer edge and rotate counterclockwise. One diaphragm assembly will come free and the other will remain attached to the shaft. Remove the freed diaphragm and air side plate.

NOTE: Two-piece PTFE models include a PTFE diaphragm (403) in addition to the backup diaphragm (401).

5. Pull the other diaphragm assembly and the diaphragm shaft (24) out of the center housing (1). Hold the shaft flats with a 19 mm open-end wrench, and remove the outer plate (105) from the shaft. Disassemble the remaining diaphragm assembly.

For overmolded diaphragms: Pull the other diaphragm assembly and the diaphragm shaft (24) out of the center housing (1). Hold the shaft flats with a 19 mm open-end wrench and remove the diaphragm and air side plate from the shaft.

6. Inspect the diaphragm shaft (24) for wear or scratches. If it is damaged, inspect the bearings (19) in place. If the bearings are damaged, refer to page 23.
7. Reach into the center housing (1) with an o-ring pick and hook the u-cup packings (402), then pull them out of the housing. This can be done with the bearings (19) in place.
8. Clean all parts and inspect for wear or damage. Replace parts as needed.

Reassembly – Standard Diaphragms

1. Grease the shaft u-cup packings (402*) and install them so the lips face **out** of the housing (1). See FIG. 13.
2. Grease the length and ends of the diaphragm shaft (24) and slide it through the housing (1).
3. Assemble the inner diaphragm plates (104), diaphragms (401*), PTFE diaphragms (403*, if present), and outer diaphragm plates (105) *exactly* as shown in FIG. 13. These parts **must** be assembled correctly.
4. Apply medium-strength (blue) Loctite® or equivalent to the threads of the fluid-side plates (105). Hold one of the outer plates (105) with a wrench and torque the other outer plate to 27 to 34 N•m at 100 rpm maximum. Do not over-torque.
5. Align the fluid covers (101) and the center housing (1) so the arrows (A) on the covers face the same direction as the air valve (B). Secure the covers with the screws (107 and 108), handtight. Install the longer screws (108) in the top and bottom holes of the covers. See FIG. 12.
6. First, torque the longer screws (108) oppositely and evenly to 22–25 N•m, using a 13 mm socket wrench. Then torque the shorter screws (107). See **Diaphragm Kits**, page 29.
7. Reassemble the ball check valves and manifolds as explained on page 18.

Service

Reassembly – Overmolded Diaphragms



WARNING

To reduce the risk of serious injury, including amputation, do not put your fingers or hand between the air cover and the diaphragm.

1. Lubricate and install the shaft u-cup packings (402*) so the lips face **out** of the housing (1). See FIG. 13.
2. Assemble the air side plate (104) onto the diaphragm (403). The wide, radiused side of the plate must face the diaphragm. Apply medium-strength (blue) Loctite or equivalent to the threads of the diaphragm assembly. Screw the assembly into the shaft (24) hand-tight.
3. Grease the length and ends of the diaphragm shaft (24). Insert the shaft/diaphragm assembly into one side of the pump. Align the fluid cover (101) and the center housing so the arrow (A) faces the same direction as the air valve. Secure the cover with the screws (107 and 108), handtight.
4. Torque the longer screws (108) oppositely and evenly to 21–25 N•m (190–220 in-lb), using a 13mm socket wrench. Then torque the shorter screws (107). See **Diaphragm Kits**, page 29.

5. Assemble the other diaphragm assembly to the shaft as explained in step 2. This diaphragm will be lifted off the air cover at this point.
6. Supply the pump with low pressure air (less than 0.5 bar [0.05 MPa, 7 psi]). The diaphragm will very slowly pull onto the air cover. Find the pressure that keeps the diaphragm close enough to secure with the screws, but does not let it contact the pilot pin.

NOTE: Do not deform the diaphragm manually. The diaphragm needs uniform pressure to deform properly for maximum life.

7. Align the fluid cover (101) and the center housing (1) so the arrow (A) faces the same direction as the air valve. Secure the cover with two of the longer screws (108), handtight.

NOTE: If the diaphragm contacts the pilot pin and is forced away from the air cover, try Step 5 again. If necessary, return to Step 3.

8. Torque the longer screws (108) oppositely and evenly to 21–25 N•m (190–220 in-lb), using a 13mm socket wrench. Then torque the shorter screws (107). See **Diaphragm Kits**, page 29.
9. Reassemble the ball check valves and manifolds as explained on page 18.

Service

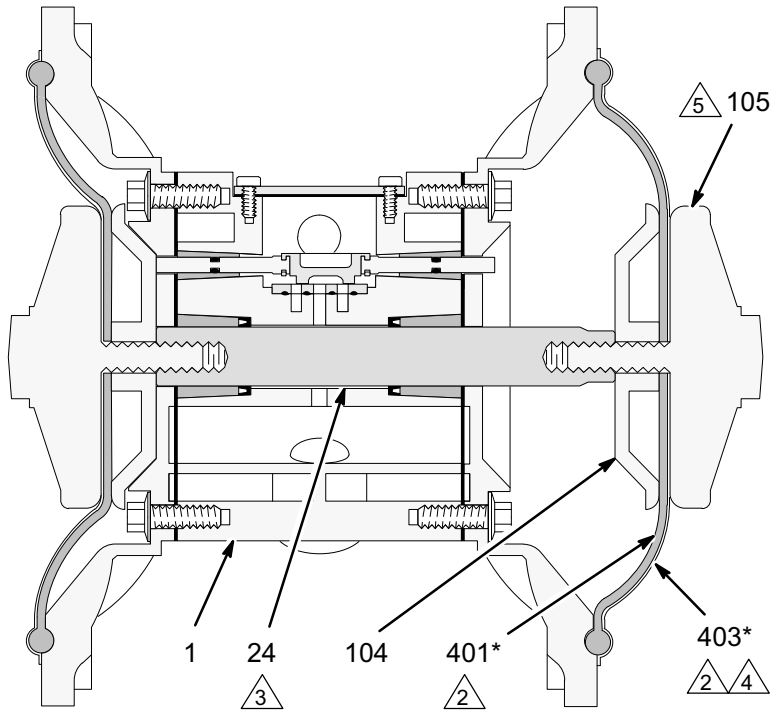

Cutaway View, with Diaphragms in Place

04708

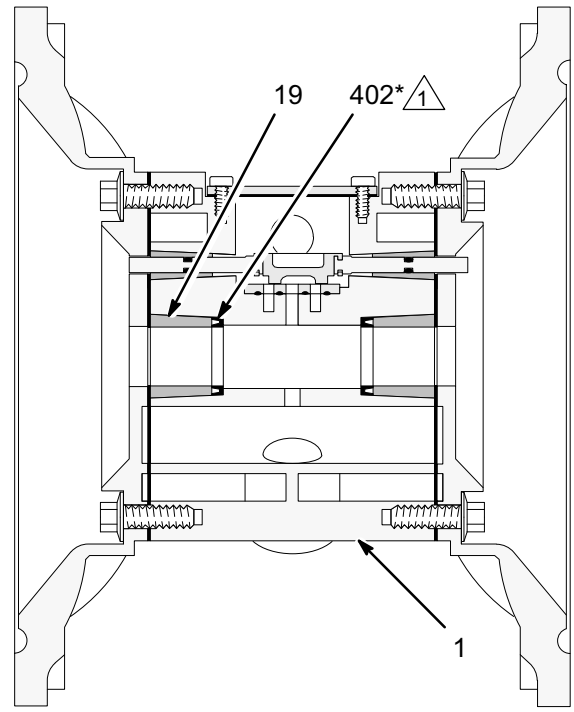

Cutaway View, with Diaphragms Removed

03982

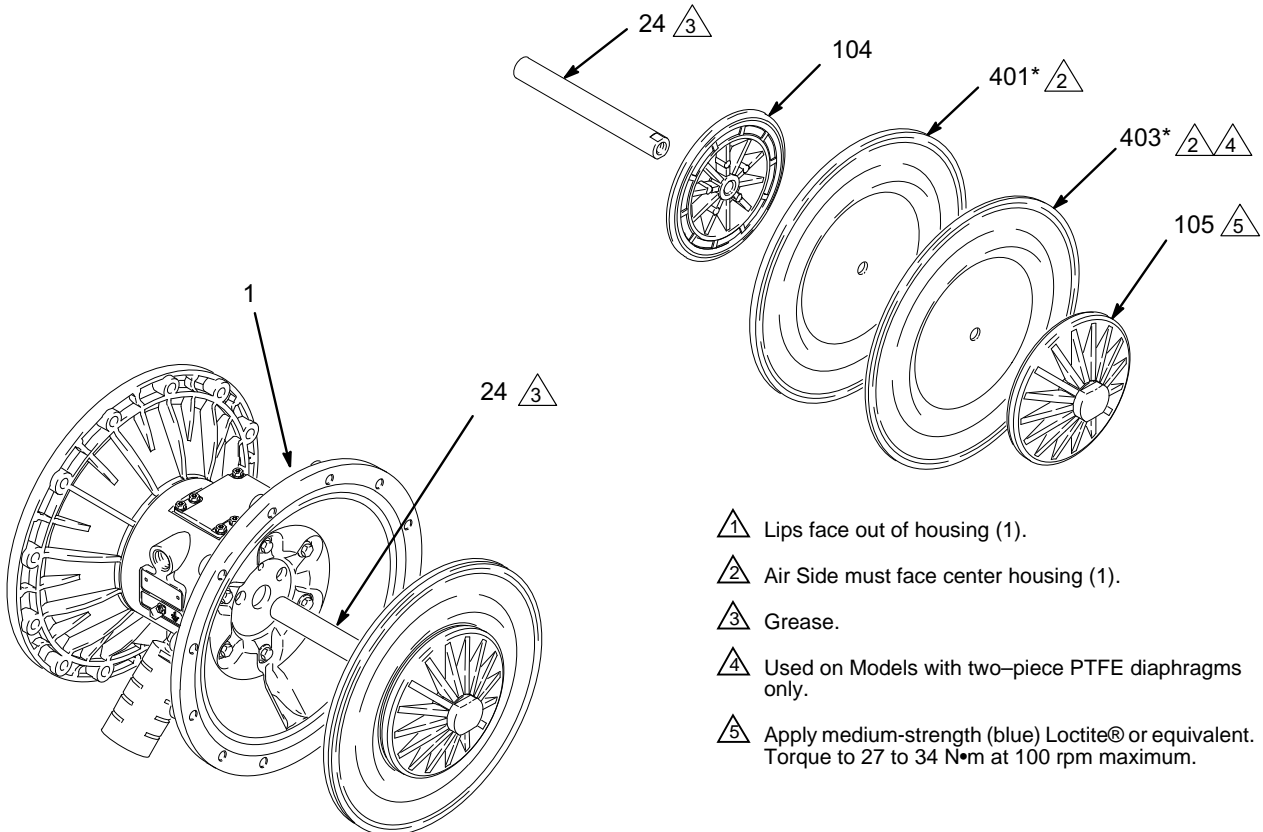

- △1 Lips face out of housing (1).
- △2 Air Side must face center housing (1).
- △3 Grease.
- △4 Used on Models with two-piece PTFE diaphragms only.
- △5 Apply medium-strength (blue) Loctite® or equivalent. Torque to 27 to 34 N•m at 100 rpm maximum.

FIG. 13

04621B

Service

Bearing and Air Gasket Removal

Tools Required

- Torque wrench
- 10 mm socket wrench
- Bearing puller
- O-ring pick
- Press, or block and mallet

Disassembly

NOTE: Do not remove undamaged bearings.

Warning

To reduce the risk of serious injury whenever you are instructed to relieve pressure, always follow the **Pressure Relief Procedure** on page 13.

1. **Relieve the pressure.**
2. Remove the manifolds and disassemble the ball check valves as explained on page 18.
3. Remove the fluid covers and diaphragm assemblies as explained on page 19.

NOTE: If you are removing only the diaphragm shaft bearing (19), skip step 4.

4. Disassemble the air valve as explained on page 16.
5. Using a 10 mm socket wrench, remove the screws (25) holding the air covers (23) to the center housing (1). See FIG. 14.

6. Remove the air cover gaskets (22). Always replace the gaskets with new ones.
7. Use a bearing puller to remove the diaphragm shaft bearings (19), air valve bearings (12) or pilot pin bearings (15). Do not remove undamaged bearings.
8. If you removed the diaphragm shaft bearings (19), reach into the center housing (1) with an o-ring pick and hook the u-cup packings (402), then pull them out of the housing. Inspect the packings. See FIG. 13.

Reassembly

1. If removed, install the shaft u-cup packings (402*) so the lips face **out** of the housing (1).
2. The bearings (19, 12, and 15) are tapered and can only be installed one way. Insert the bearings into the center housing (1), **tapered end first**. Using a press or a block and rubber mallet, press-fit the bearing so it is flush with the surface of the center housing.
3. Reassemble the air valve as explained on page 17.
4. Align the new air cover gasket (22) so the pilot pin (16) protruding from the center housing (1) fits through the proper hole (H) in the gasket.
5. Align the air cover (23) so the pilot pin (16) fits in the middle hole (M) of the three small holes near the center of the cover. Install the screws (25), handtight. See Fig. 14. Using a 10 mm socket wrench, torque the screws oppositely and evenly to 15–17 N•m.
6. Install the diaphragm assemblies and fluid covers as explained on page 19.
7. Reassemble the ball check valves and manifolds as explained on page 18.

Service

- ⚠ Insert bearings tapered end first.
- ⚠ Press-fit bearings flush with surface of center housing (1).
- ⚠ Torque to 15–17 N•m.

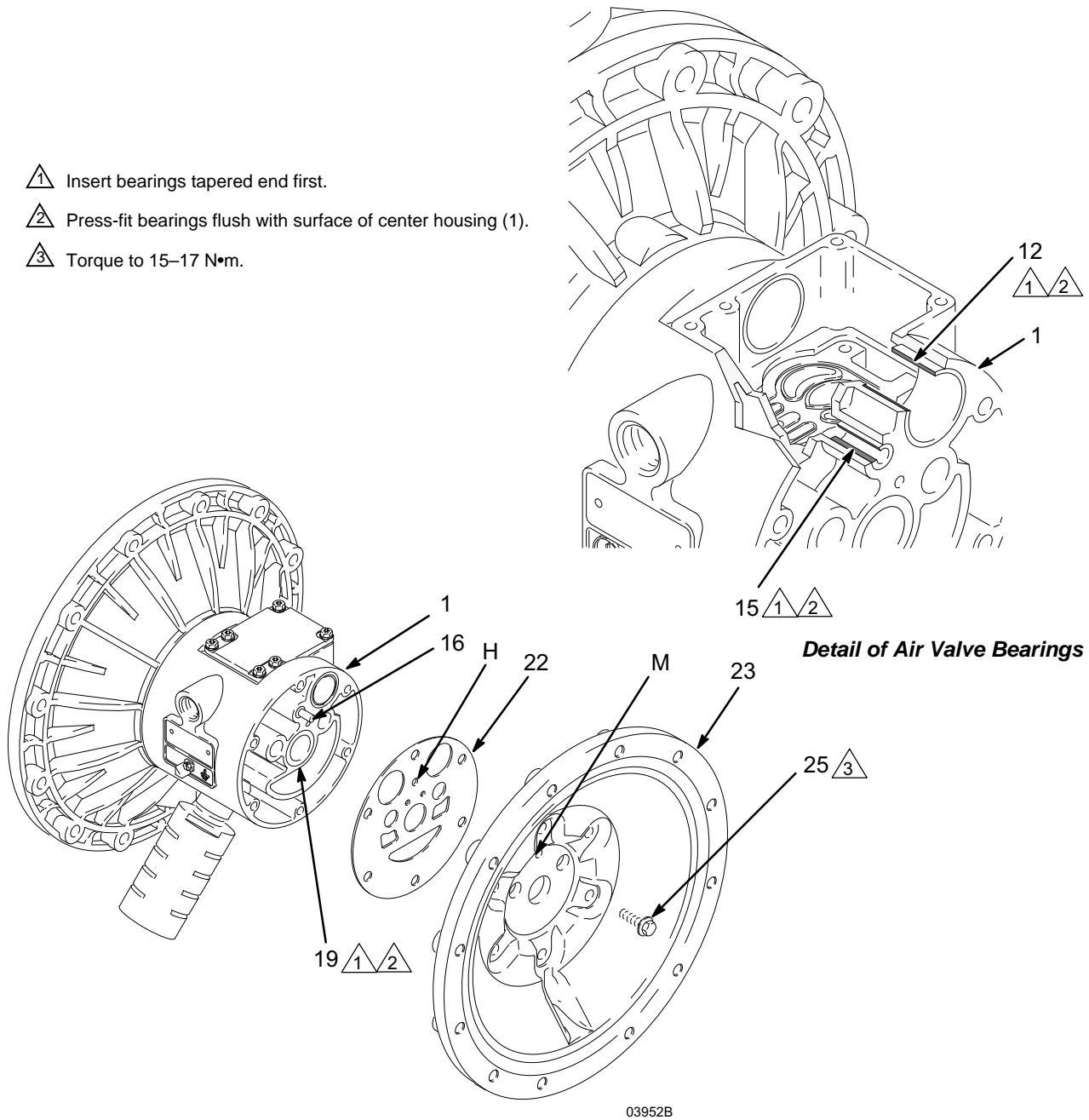

03951

03952B

FIG. 14

Repair Kit Listing

For **VERDERAIR VA 50** Polypropylene and PVDF pumps, Series **B**

Repair Kits may only be ordered as kits. To repair the air valve, order **Part No. 819.4274** for aluminum center housing models and **Part No. 819.0249** for stainless steel center housing models (see page 28). Parts included in the Air Valve Repair Kit are marked with a symbol in the parts list, for example (4+■). The list of existing Repair Kits is below:

Part No.	Seats	Balls	Diaphragms	O-Rings
819.0036	VT	SP	SP	--
819.0037	VT	--	--	--
819.0038	BN	BN	BN	--
819.0039	BN	SP	SP	--
819.0040	BN	TF	TF	--
819.0041	BN	--	--	--
819.0042	--	BN	--	--
819.0043	--	--	BN	--
819.0257	--	--	--	EP
819.3803	PP	GE	GE	TF
819.4509	--	--	TF	--
819.4510	--	--	HY	--
819.4511	--	--	SP	--
819.4512	--	--	VT	--
819.4513	--	TF	--	--
819.4533	--	SP	--	--
819.4538	--	VT	--	--
819.4549	SS	TF	TF	TF
819.4559	SS	HS	TF	TF
819.4562	SS	HS	VT	TF
819.4565	SS	HY	HY	TF
819.4571	SS	SP	SP	TF
819.4572	SS	SP	VT	TF
819.4577	SS	VT	VT	TF
819.4584	HS	TF	TF	TF
819.4594	HS	HS	TF	TF
819.4606	HS	SP	SP	TF
819.4619	HY	TF	TF	--
819.4622	HY	TF	VT	--
819.4625	HY	AC	HY	--
819.4633	HY	HY	--	--
819.4635	HY	HY	HY	--
819.4651	SP	--	SP	TF
819.4654	SP	TF	TF	TF

Part No.	Seats	Balls	Diaphragms	O-Rings
819.4673	SP	SP	--	TF
819.4676	SP	SP	SP	TF
819.4688	PP	TF	--	TF
819.4689	PP	TF	TF	TF
819.4691	PP	TF	SP	TF
819.4692	PP	TF	VT	TF
819.4703	PP	HY	--	TF
819.4705	PP	HY	HY	TF
819.4708	PP	SP	--	TF
819.4711	PP	SP	SP	TF
819.4713	PP	VT	--	TF
819.4714	PP	VT	TF	TF
819.4717	PP	VT	VT	TF
819.4718	KY	--	--	TF
819.4723	KY	TF	--	TF
819.4724	KY	TF	TF	TF
819.4726	KY	TF	SP	TF
819.4746	KY	SP	SP	TF
819.4748	KY	VT	--	TF
819.4752	KY	VT	VT	TF
819.1321	PP	TF	TO	TF
819.4550	SS	TF	HY	TF
819.4613	HY	--	--	--
819.4683	PP	--	--	TF
819.4648	SP	--	--	TF
819.4543	SS	--	--	TF
819.4518	--	AC	--	--
819.4528	--	HY	--	--
819.4523	--	HS	--	--
819.1361	--	--	TO	--

EP = Ethylene propylene diene monomer (EPDM)
 HY = TPE KY = PVDF
 PP = Polypropylene SP = Santoprene SS = Stainless Steel
 TF = PTFE TO = PTFE/EPDM Overmolded
 VT = Fluoroelastomer -- = NULL

Overmolded PTFE Diaphragm Kits

819.0397 – VA 50 HD Overmolded PTFE repairkit

819.0398 – VA 50 HD Overmolded PTFE repair kit with new air-side diaphragm plates

NOTE: Heavy-duty overmolded diaphragms require new air-side diaphragm plates. If a bolt-through diaphragm was in use, you must purchase 819.0398, the kit that includes the new plates.

Parts

Air Motor Parts List

Ref. No.	Part No.	Description	Qty
1	819.4275	HOUSING, center; alum.	1
	819.0247	HOUSING, center; stainless steel	1
2	819.4276	COVER, air valve; alum.	1
	819.0259	COVER, air valve; stainless steel	1
3	819.0221	SCREW, mach, hex flange hd; M5 x 0.8; 12 mm	9
4†■	819.4278	GASKET, cover; Santoprene®	1
5	819.4279	CARRIAGE; aluminum	1
6†■	819.4280	O-RING; nitrile	1
7†■	819.4281	BLOCK, air valve; acetal	1
8■	819.4282	PLATE, air valve; sst	1
9†	819.4283	SEAL, valve plate; buna-N	1
10†■	819.4284	PACKING, u-cup; nitrile	2
11	819.4285	PISTON, actuator; acetal	2
12	819.4286	BEARING, piston; acetal	2
15	819.4287	BEARING, pin; acetal	2
16	819.4288	PIN, pilot; stainless steel	2
17†■	819.4289	O-RING; buna-N	2
18†■	819.4290	BLOCK, pilot; acetal	1
19	819.4291	BEARING, shaft; acetal	2
20	819.0220	SCREW, grounding	1
22	819.4294	GASKET, air cover; foam	2
23	819.4295	COVER, air; aluminum	2
	819.7110	COVER, air; stainless steel	2
24	819.4296	SHAFT, diaphragm; sst	1
25	819.7051	SCREW; M8 x 1.25; 25 mm	12

Fluid Section Parts List

Fluid Section Material	Ref. No.			
P O L Y P R O P Y L E (P) or (C)	101	819.4497	COVER, fluid; polypropylene	2
		819.0279	COVER, fluid; conductive polypropylene	2
	102	819.4498	MANIFOLD, inlet; polypropylene	1
		819.0278	MANIFOLD, inlet; conductive polypropylene	1
	103	819.4499	MANIFOLD, outlet; polypropylene	1
		819.0288	MANIFOLD, outlet; conductive polypropylene	1
	104	819.4301	PLATE, air side; aluminum	2
	105	819.4500	PLATE, fluid side; polypropylene	2
	106	819.4375	SCREW; M8 x 1.25; 70 mm; sst	8
	107	819.4491	SCREW; M10 x 1.50; 60 mm; sst	16
	108	819.9753	SCREW; M10 x 1.50; 110 mm; sst	8
	110▲	819.6314	LABEL, warning	1
	111	819.7000	MUFFLER	1
	112	819.4377	SCREW; M8 x 1.25; 40 mm; sst	8
113	819.9758	WASHER; manifold; outlet	4	
114	819.9759	WASHER; manifold; inlet	4	

Fluid Section Parts List (continued)

P
O
L
Y
-
V
I
N
Y
L
I
D
E
N
E
F
L
U
O
R
I
D
E
(K)

101	819.4501	COVER, fluid; PVDF	2
102	819.4502	MANIFOLD, inlet; PVDF	1
103	819.4503	MANIFOLD, outlet; PVDF	1
104	819.4301	PLATE, air side; aluminum	2
105	819.4504	PLATE, fluid side; PVDF	2
106	819.4375	SCREW; M8 x 1.25; 70 mm; sst	8
107	819.4491	SCREW; M10 x 1.50; 60 mm; sst	16
108	819.9753	SCREW; M10 x 1.50; 110 mm; sst	8
110▲	819.6314	LABEL, warning	1
111	819.7000	MUFFLER	1
112	819.4377	SCREW; M8 x 1.25; 40 mm; sst	8
113	819.9758	WASHER; manifold; outlet	4
114	819.9759	WASHER; manifold; inlet	4

Parts

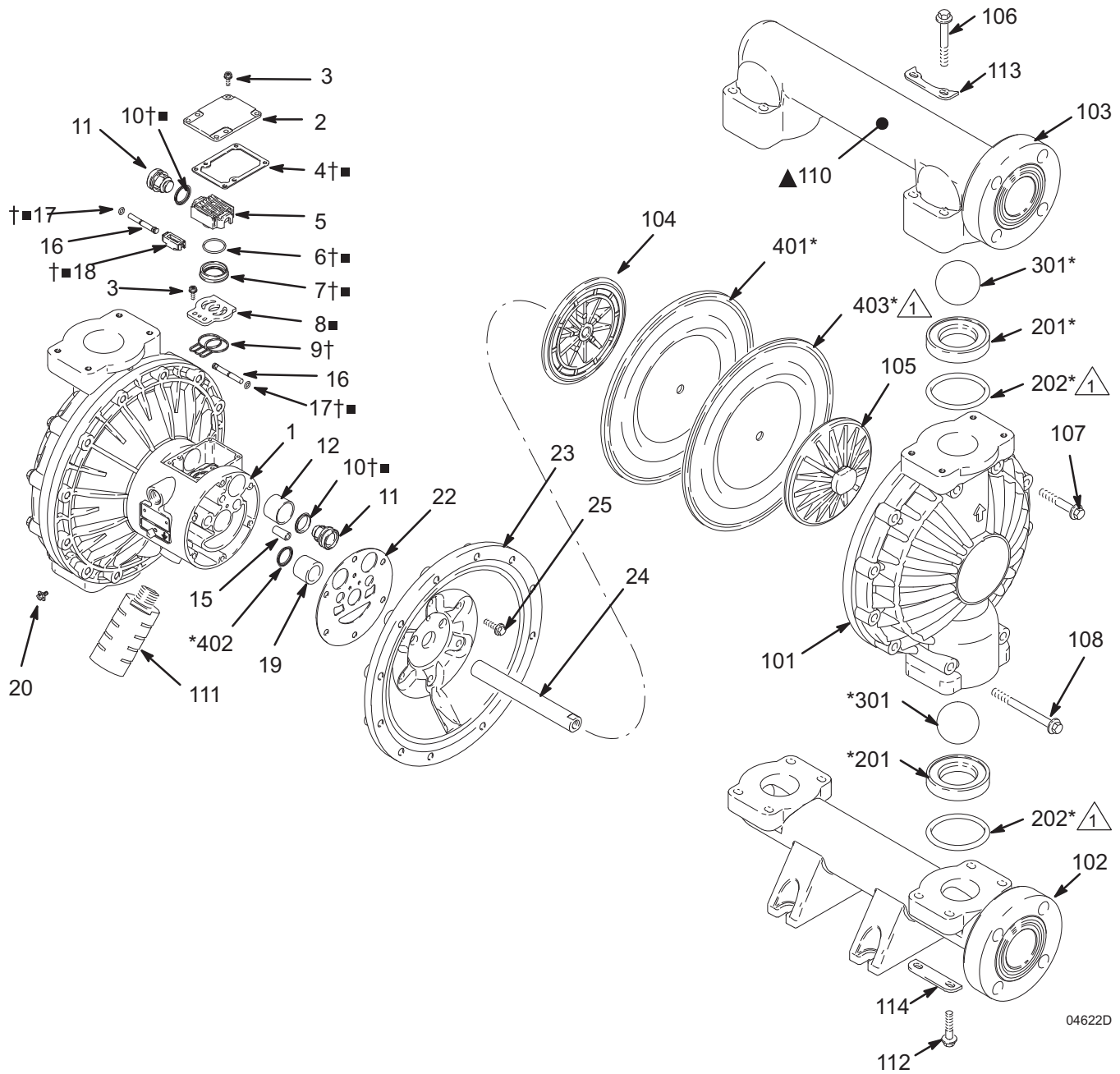

04622D

▲ Not used on some models.

* These parts are included in the Pump Repair Kit, which may only be purchased as a kit. Refer to the Repair Kit Listing on page 27 to determine the correct kit for your pump.

† These parts are included in Air Valve Repair Kit 819.4274 (aluminum center housing models), which may only be purchased as a kit.

■ These parts are included in Air Valve Repair Kit 819.0249 (stainless steel center housing models), which may only be purchased as a kit.

▲ Replacement Danger and Warning labels, tags and cards are available at no cost.

Parts

Valve Seat Kits

Seat Material	Ref. No.	Kit No.	Description	Qty
BN	201	819.0041	VA50P BN,--,--,--	1
	202	Not required		
HY	201	819.4613	VA50P HY,--,--,--	1
	202	Not required		
KY	201	819.4718	VA50P KY,--,--,TF	1
	202	Included in above kit		
PP	201	819.4683	VA50P PP,--,--,TF	1
	202	Included in above kit		
SP	201	819.4648	VA50P SP,--,--,TF	1
	202	Included in above kit		
SS	201	819.4543	VA50P SS,--,--,TF	1
	202	Included in above kit		
VT	201	819.0037	VA50P VT,--,--,--	1
	202	Not required		

Diaphragm Kits

Diaphragm Material	Ref. No.	Kit No.	Description	Qty
BN	401	819.0043	VA50P --,--,BN,--	1
	402	Included in above kit		
HY	401	819.4510	VA50P --,--,HY,--	1
	402	Included in above kit		
SP	401	819.4511	VA50P --,--,SP,--	1
	402	Included in above kit		
TF	401	819.4509	VA50P --,--,TF,--	1
	402	Included in above kit		
	403	Included in above kit		
TO	401	819.1361	VA50P --,--,TO,--	1
	402	Included in above kit		
VT	401	819.4512	VA50P --,--,VT,--	1
	402	Included in above kit		

Check Ball Kits

Ball Material	Ref. No.	Kit No.	Description	Qty
AC	301	819.4518	VA50P --,AC,--,--	1
BN	301	819.0042	VA50P --,BN,--,--	1
HY	301	819.4528	VA50P --,HY,--,--	1
VT	301	819.4538	VA50P --,VT,--,--	1
SP	301	819.4533	VA50P --,SP,--,--	1
HS	301	819.4523	VA50P --,HS,--,--	1
TF	301	819.4513	VA50P --,TF,--,--	1

Torque Sequence

Always follow torque sequence when instructed to torque fasteners.

1. Left/Right Fluid Covers
Torque bolts to 22–25 N•m.

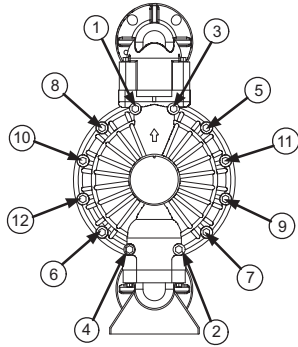

SIDE VIEW

3. Outlet Manifold
Torque bolts to 17–18 N•m

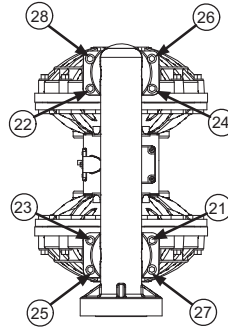

BOTTOM VIEW

2. Inlet Manifold
Torque bolts to 17–18 N•m

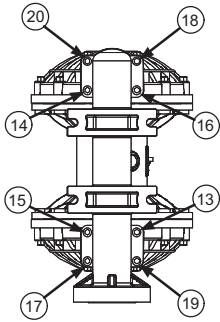

BOTTOM VIEW

Dimensions

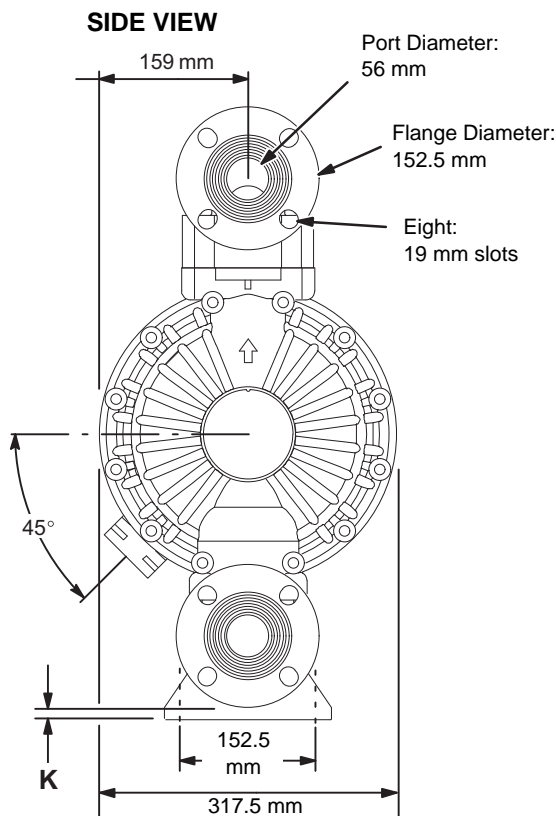
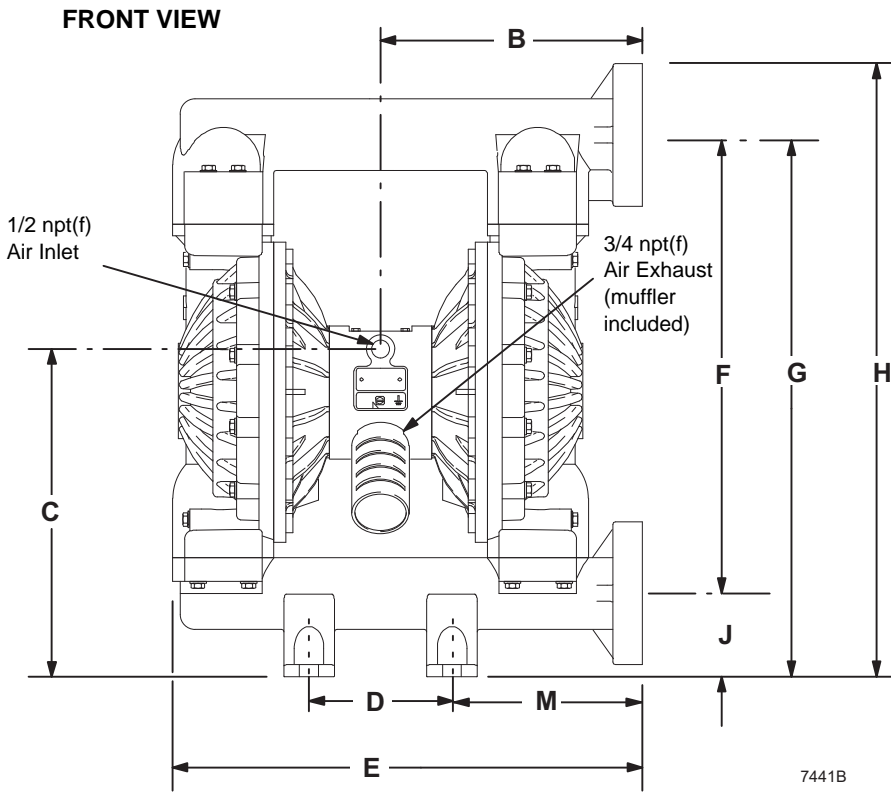

Dimensions B, C, F, G, H, and M can vary by up to 1/4 in. (6.3 mm) depending on the seat and diaphragm material fitted in the pump.

PUMP MOUNTING HOLE PATTERN

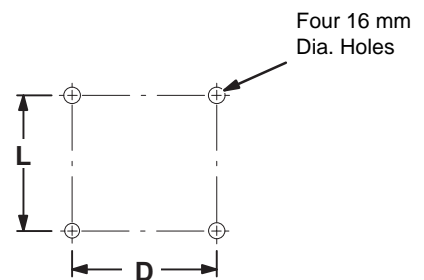

Dimensions

Dimension	SST Center Polypropylene Cover		SST Center PVDF Cover		Aluminum Center Polypropylene Cover		Aluminum Center PVDF Cover	
	in.	mm	in.	mm	in.	mm	in.	mm
B	11.0	280	11.0	280	11.0	280	11.0	280
C	13.7	349	13.6	345	13.7	349	13.6	345
D	6.0	152	6.0	152	6.0	152	6.0	152
E	19.7	501	19.6	499	19.7	501	19.6	499
F	19.2	487	19.1	484	19.2	487	19.1	484
G	22.7	576	22.6	573	22.7	576	22.6	573
H	25.7	652	25.6	649	25.7	652	25.6	649
J	3.5	89	3.5	89	3.5	89	3.5	89
K	0.5	13	0.5	13	0.5	13	0.5	13
L	6.0	152	6.0	152	6.0	152	6.0	152
M	8.0	203	8.0	203	8.0	203	8.0	203

Technical Data

Maximum Fluid Working Pressure	8.3 bar	Fluid Outlet Size.	2 in. Raised Face Flange
Air Pressure Operating Range	1.4–8.3 bar	ANSI/DIN 50 Flange	2 in. (50 mm)
Maximum Air Consumption	4.9 N m ³ /min	Wetted Parts	Vary by Model. Refer to pages 26–29
Air Consumption		Non-wetted External Parts	Aluminum,
at 4.9 bar/227 l/min	1.68 N m ³ /min (see chart)		302, 316 Stainless Steel, Polyester (labels)
Maximum Free Flow Delivery	568 l/min	Weight	<i>Polypropylene Pumps</i>
Maximum Pump Speed	145 cpm		<i>with Aluminum Air Section: 22 kg</i>
Liters per cycle	3.90		<i>PVDF Pumps</i>
Maximum Suction Lift	5.48 m wet or dry		<i>with Aluminum Air Section: 31 kg</i>
Maximum Size Pumpable Solids	6.3 mm		<i>Polypropylene Pumps</i>
* Sound pressure Level at 7 bar, 50 cpm	90 dBa		<i>with Stainless Steel Air Section: 32 kg</i>
* Sound Power Level at 7 bar, 50 cpm	103 dBa		<i>PVDF Pumps</i>
* Sound Pressure Level at 4.9 bar, 50 cycles/min	85 dBa		<i>with Stainless Steel Air Section: 41 kg</i>
Maximum Operating Temperature	65.5°C		
Air Inlet Size	1/2 npt(f)	Santoprene® is a registered trademark of the Monsanto	Co.
Fluid Inlet Size.	2 in. Raised Face Flange	* <i>Sound pressure levels measured with the pump</i>	
ANSI/DIN 50 Flange	2 in. (50 mm)	<i>mounted on the floor, using Rubber Foot Kit 819.4333.</i>	
		<i>Sound power measured per ISO Standard 9614–2.</i>	

Fluid Temperature Range

NOTICE

Temperature limits are based on mechanical stress only. Certain chemicals will further limit the fluid temperature range. Stay within the temperature range of the most-restricted wetted component. Operating at a fluid temperature that is too high or too low for the components of your pump may cause equipment damage.

Diaphragm/Ball/Seat Material	Fluid Temperature Range					
	Aluminum, Hastelloy, or Stainless Steel Pumps		Polypropylene or Conductive Polypropylene Pumps		PVDF Pumps	
	Fahrenheit	Celsius	Fahrenheit	Celsius	Fahrenheit	Celsius
Acetal (AC)	10° to 180°F	-12° to 82°C	32° to 150°F	0° to 66°C	10° to 180°F	-12° to 82°C
Buna-N (BN)	10° to 180°F	-12° to 82°C	32° to 150°F	0° to 66°C	10° to 180°F	-12° to 82°C
FKM Fluoroelastomer (FK)*	-40° to 275°F	-40° to 135°C	32° to 150°F	0° to 66°C	10° to 225°F	-12° to 107°C
Geolast® (GE)	-40° to 150°F	-40° to 66°C	32° to 150°F	0° to 66°C	10° to 150°F	-12° to 66°C
Polychloroprene overmolded diaphragm (CO) or Polychloroprene check balls (CR or CW)	0° to 180°F	-18° to 82°C	32° to 150°F	0° to 66°C	10° to 180°F	-12° to 82°C
Polypropylene (PP)	32° to 150°F	0° to 66°C	32° to 150°F	0° to 66°C	32° to 150°F	0° to 66°C
PTFE overmolded diaphragm (PO)	40° to 180°F	4° to 82°C	40° to 150°F	4° to 66°C	40° to 180°F	4.0° to 82°C
PTFE check balls or two-piece PTFE/EPDM diaphragm (PT)	40° to 220°F	4° to 104°C	40° to 150°F	4° to 66°C	40° to 220°F	4° to 104°C
PVDF (PV)	10° to 225°F	-12° to 107°C	32° to 150°F	0° to 66°C	10° to 225°F	-12° to 107°C
Santoprene® (SP)	-40° to 180°F	-40° to 82°C	32° to 150°F	0° to 66°C	10° to 180°F	-12° to 82°C
TPE (TP)	-20° to 150°F	-29° to 66°C	32° to 150°F	0° to 66°C	10° to 150°F	-12° to 66°C

* The maximum temperature listed is based on the ATEX standard for T4 temperature classification. If you are operating in a non-explosive environment, FKM fluoroelastomer's maximum fluid temperature in aluminum or stainless steel pumps is 320°F (160°C).

Performance Chart

Example of Finding Pump Air Consumption and Air Pressure at a Specific Fluid Delivery and Discharge Head:

To supply 227 liters fluid flow (horizontal scale) at 2.8 bar discharge head pressure (vertical scale) requires approximately 1.68 N m³/min air consumption at 4.9 bar inlet air pressure.

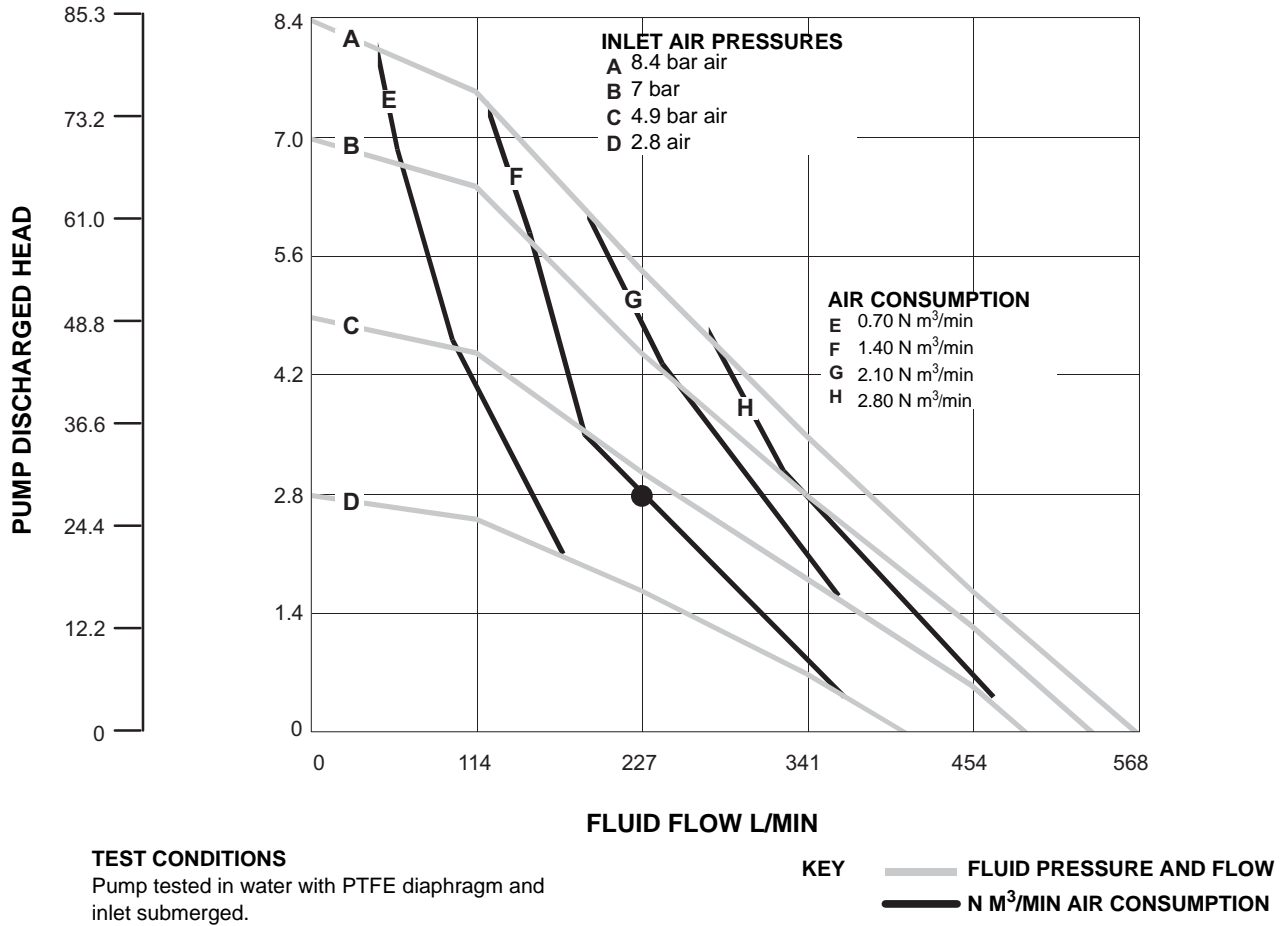

Customer Services/Guarantee

CUSTOMER SERVICES

If you require spare parts, please contact your local distributor, providing the following details:

- Pump Model
- Type
- Serial Number, and
- Date of First Order.

GUARANTEE

All VERDER pumps are warranted to the original user against defects in workmanship or materials under normal use (rental use excluded) for two years after purchase date. This warranty does not cover failure of parts or components due to normal wear, damage or failure which in the judgement of VERDER arises from misuse.

Parts determined by VERDER to be defective in material or workmanship will be repaired or replaced.

LIMITATION OF LIABILITY

To the extent allowable under applicable law, VERDER's liability for consequential damages is expressly disclaimed. VERDER's liability in all events is limited and shall not exceed the purchase price.

WARRANTY DISCLAIMER

VERDER has made an effort to illustrate and describe the products in the enclosed brochure accurately; however, such illustrations and descriptions are for the sole purpose of identification and do not express or imply a warranty that the products are merchantable, or fit for a particular purpose, or that the products will necessarily conform to the illustration or descriptions.

PRODUCT SUITABILITY

Many regions, states and localities have codes and regulations governing the sale, construction, installation and/or use of products for certain purposes, which may vary from those in neighbouring areas. While VERDER attempts to assure that its products comply with such codes, it cannot guarantee compliance, and cannot be responsible for how the product is installed or used.

Before purchasing and using a product, please review the product application as well as the national and local codes and regulations, and be sure that product, installation, and use complies with them.

Original instructions. This manual contains English.
Revision ZAL, December 2019

Austria

Verder Austria
Eitnergasse 21/Top 8
A-1230 Wien
AUSTRIA
Tel: +43 1 86 51 074 0
Fax: +43 1 86 51 076
e-mail: office@verder.at

Belgium

Verder nv
Kontichsesteenweg 17
B-2630 Aartselaar
BELGIUM
Tel: +32 3 877 11 12
Fax: +32 3 877 05 75
e-mail: info@verder.be

China

Verder Shanghai Instruments and Equipment Co., Ltd
Building 8 Fuhai Business Park No. 299
Bisheng Road, Zhangjiang Hiteck Park
Shanghai 201204
CHINA
Tel: +86 21 33932950
Fax: +86 21 33932955
e-mail: info@verder.cn

Bulgaria

Verder Bulgaria Ltd
Vitosh department,
Manastriski Livadi Zapad
district,
110 Bulgaria Blvd., 2-nd
Floor, apt. 15-16,
1618 - Sofia
BULGARIA
Tel: 0878407370
Fax: 02 9584085
email: office@verder.bg

Czech Republic

Verder s.r.o.
Vodnanská 651/6 (vchod
Chlumecka 15)
198 00 Praha 9-Kyje
CZECH REPUBLIC
Tel: +420 261 225 386-7
Web: <http://www.verder.cz>
e-mail: info@verder.cz

France

Verder France
8 Allée Rosa Luxembourg
Immeulde Arizona
95610 Eragny sur Oise
FRANCE
Tel: +33 173 43 98 41
Fax: +33 134 64 44 50
e-mail: info@verder.fr

Germany

Verder Deutschland GmbH
Retsch-Allee 1-5
42781 Haan
GERMANY
Tel: 02104/2333-200
Fax: 02104/2333-299
e-mail: info@verder.de

Hungary

Verder Hungary Kft
Budafoke ut 187 - 189
HU-1117 Budapest
HUNGARY
Tel: 0036 1 3651140
Fax: 0036 1 3725232
e-mail: info@verder.hu

India

Verder India Pumps Pvt
Ltd.
Plot No-3B, D-1 Block,
MIDC Chinchwad,
Pune - 411019
INDIA
e-mail:
Sales@verder.co.in
www.verder.co.in

Italy

Verder Italia
Via Maestri Del lavoro, 5
02100 Vazia, Rieti
ITALY
Tel: +39 07 46 229064
e-mail: info@verder.it

The Netherlands

Verder BV
Leningradweg 5
NL 9723 TP Groningen
THE NETHERLANDS
Tel: +31 50 549 59 00
Fax: +31 50 549 59 01
e-mail: info@verder.nl

Poland

Verder Polska
ul.Porcelanowa 23
PL-40 036 Katowice
POLAND
Tel: +48 32 78 15 032
Fax: +48 32 78 15 034
e-mail: verder@verder.pl

Romania

Verder România
Drumul Balta Doamnei
no 57-61
Sector 3
CP 72-117
032624 Bucuresti
ROMANIA
Tel: +40 21 335 45 92
Fax: +40 21 337 33 92
e-mail: office@verder.ro

Slovak Republik

Verder Slovakia s.r.o.
Silacska 1
SK-831 02 Bratislava
SLOVAK REPUBLIK
Tel: +421 2 4463 07 88
Fax: +421 2 4445 65 78
e-mail: info@verder.sk

South Africa

Verder SA
197 Flaming Rock Avenue
Northlands Business Park
Newmarket Street
ZA Northriding
SOUTH AFRICA
Tel: +27 11 704 7500
Fax: +27 11 704 7515
e-mail: info@verder.co.za

Switzerland

Verder Deutschland GmbH
Sales Switzerland
Retsch-Allee 1-5
D-42781 Haan
GERMANY
Tel: +41 (0)61 331 33 13
Fax: +41 (0)61 331 63 22
e-mail: info@verder.ch

United Kingdom

Verder UK Ltd.
Unit 3 California Drive
Castleford, WF10 5QH
UNITED KINGDOM
Tel: +44 (0) 1924 221 001
Fax: +44 (0) 1132 465 649
e-mail: info@verder.co.uk

United States of America

Verder Inc.
312 Corporate Parkway
Suite 101
Macon, GA 31210
USA
Tel: +1 877 783 7337
Fax: +1 478 476 9867
e-mail: sales@verder-us.com